

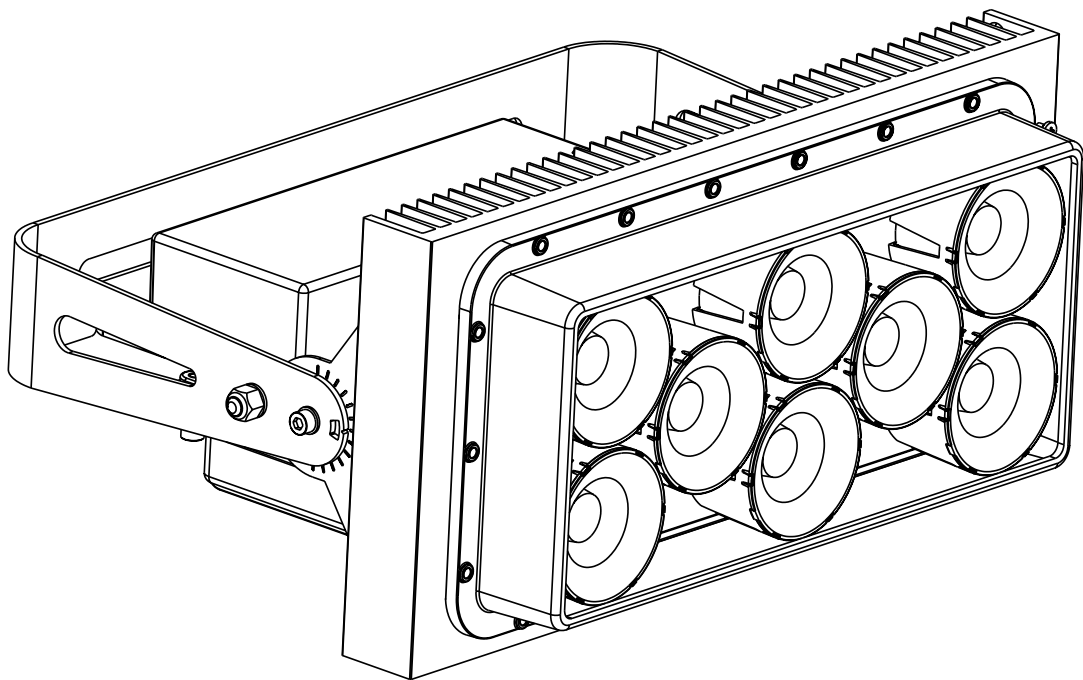

# SunLite LED

User Manual



# SunLite LED

## User Manual

Serial Number:

.....

Purchase date:

.....

Dealer:

.....

Address:

.....

Suburb:

.....

Country:

.....

Phone / Fax:

.....

Please note in the space provided above the relative service information of the model and the retailer from whom you purchased your **SunLite LED Series**: this information will assist us in providing spare parts, repairs or in answering any technical enquiries with the utmost speed and accuracy.

**WARNING:** the security of the fixture is granted only if these instructions are strictly followed; therefore it is absolutely necessary to keep this manual.

# Index

<b>1. Packaging and transportation</b> .....	Pag. 5
<b>1.1</b> Packaging .....	Pag. 5
<b>1.2</b> Transportation .....	Pag. 5
<b>2. General information</b> .....	Pag. 5
<b>2.1</b> Safety informations .....	Pag. 5
<b>2.2</b> Warranty conditions .....	Pag. 6
<b>2.3</b> EC norms .....	Pag. 6
<b>3. Product specifications</b> .....	Pag. 7
<b>3.1</b> Technical characteristics .....	Pag. 7
<b>3.2</b> Dimensions .....	Pag. 7
<b>3.3</b> Unit's main components .....	Pag. 8
<b>3.4</b> Back panel description .....	Pag. 9
<b>4. Installation</b> .....	Pag. 10
<b>4.1</b> Mechanical installation .....	Pag. 10
<b>4.2</b> Safety chain .....	Pag. 10
<b>4.3</b> How to change the optical lenses .....	Pag. 11
<b>4.4</b> How to mount the Louver .....	Pag. 13
<b>5. Powering up</b> .....	Pag. 14
<b>5.1</b> Operating voltage and frequency .....	Pag. 14
<b>5.2</b> Connection to mains power .....	Pag. 14
<b>6. Control signal connections</b> .....	Pag. 15
<b>6.1</b> Control signal connection by XLR5 plugs .....	Pag. 15
<b>7. Turning on the projector</b> .....	Pag. 16
<b>8. Setup via RDM</b> .....	Pag. 16
<b>8.1</b> Quick guide to menu .....	Pag. 16
<b>8.2</b> RDM Chart .....	Pag. 16
<b>8.3</b> RDM Error Chart .....	Pag. 17
<b>9. DMX Chart</b> .....	Pag. 18
<b>9.1</b> DMX Chart 5 channels .....	Pag. 18
<b>9.2</b> DMX Chart 2/1 channels .....	Pag. 19
<b>9.3</b> DMX Chart Sunrise mode .....	Pag. 20
<b>9.4</b> DMX Chart Raw mode .....	Pag. 21
<b>10. Accessories and spare parts</b> .....	Pag. 22
<b>11. Maintenance</b> .....	Pag. 22
<b>11.1</b> Firmware update .....	Pag. 22
<b>11.2</b> Periodic cleaning .....	Pag. 22
<b>11.3</b> Periodic controls .....	Pag. 23
<b>11.4</b> Fuses .....	Pag. 23
<b>12. F.A.Q. and answers</b> .....	Pag. 23

Congratulations on having purchased a **Coemar** product. You have assured yourself of a fixture of the highest quality, both in componentry and in the technology used. We renew our invitation to you to complete the service information on the previous page, to expedite any request for service information or spares (in case of problems encountered either during, or subsequent to, installation). This information will assist in providing prompt and accurate advice from your **Coemar** service centre. Following the instructions and procedures outlined in this manual will ensure the maximum efficiency of this product for years to come.

# 1. Packaging and transportation



## 1.1 Packaging

Open the packaging and make sure that no part of the equipment has suffered any damage during the transportation. In case of damage to the fixture, contact your carrier and your supplier immediately by telephone, fax or email, and inform them you will formally notify them in writing through registered letter.

### Packing list

Ensure the packaging contains:

**1 SunLite LED**

**1 Instruction manual**

## 1.2 Transportation

The **SunLite LED** should be transported in either its original packaging or in an appropriate flight case.

# 2. General information



## 2.1 Safety informations

### Fire prevention:



1. Never locate the fixture on any flammable surface.
2. Minimum distance from flammable materials: 0,5 m.
3. Minimum distance from the closet illuminable surface: 0,5 m.
4. Connect the projector to mains power protected by a thermal magnetic circuit breaker.
5. Install only in a well-ventilated space.
6. Install only in accordance with applicable building codes.
7. Do not paint, cover, or modify the device, and do not filter or mask the light.
8. Allow the device to cool for 15 minutes after operation before touching it.



### Protection rating of the body against liquids and solids:



1. This projector has an **IP 65** protection rating; this indicates that it is protected against dust and significant showers of water. This protection rating allows the fixture to be installed in an exposed location in inclement weather.

### Prevention from electric shock:



1. Presence of high voltage inside of the fixture. Insulate the projector from mains supply before opening or performing any function which involves touching the inside of the fixture, including lamp replacement.
2. For the connection to the mains, adhere strictly to the guidelines outlined in this manual.
3. The level of technology of **SunLite LED** requires the use of specialised personnel for all service applications; refer all work to your authorised **Coemar** service centre.
4. A good earth connection is essential for the proper functioning of the projector.
5. Never connect the fixture if there is no earth connection.
6. Mains cables must not come into contact with other cables.
7. Do not operate the projector with wet hands or in an area where water is present.
8. The fixture must never be located in an exposed position, or in areas of extreme humidity.
9. Do not immerse the fixture in water or liquid.
10. Do not apply power if the device or mains cable is in any way damaged.



### Safety:



1. The projector must always be installed with bolts, clamps, or other fixing devices which are suitably rated to support the weight of the projector.
2. Always use a secondary safety fixing device with chain or steel wire of a suitable rating to sustain the weight of the unit in case of failure of the principal fixing point.
3. Devices and accessories must be secured against fall when mounted above floor level. Always observe common and local safety regulations.
4. The stirrup must be mounted hanging or standing vertically. Lateral load can cause deformation or breaking of the spigot and the stirrup.
5. The external surfaces of the unit, at various points, may reach 80°C. Never handle the unit until at least 10 minutes have elapsed since the LED was turned off.
6. Never install the fixture in an enclosed area lacking sufficient air flow; the room temperature must not exceed 40°C.
7. The projector contains electronic and electrical components which must under no circumstances be in contact with water, oil or any other liquid. Failure to do so will compromise the proper functioning of the projector.
8. Do not operate the fixture with missing or damaged covers, shields or any optical component.
9. Do not attempt to bypass thermostatic switches or fuses.



10. For elevated installations, secure the fixture with suitable safety cables, and always comply with relevant load dimensioning, safety standards, and requirements.
11. Caution! High intensity light emission. Risk of eye injury.
12. Take precautions when working at height to prevent injury due to falls.
13. Do not look directly at the light source from close range.
14. Provide well-lit conditions to reduce the pupil diameter of anyone working on or near the fixture.
15. Wear protective glasses and other PPE (personal protective equipment) when working on or near the fixture.
16. Ensure that persons are not looking directly into the front of the fixture when the product lights up suddenly. This can happen when power is applied, when the product receives a DMX signal, or when certain control menu items are selected.



## **DANGER! Risk of injury or death through epileptic seizure.**

Do not use the effect near stairways, in corridors or near public exits.

Provide advance notice that strobe lighting is in use. Display advisory notices on the set, at the point of ticket sales, on tickets if possible, in the program, and at the entrance(s) to the venue or studio.

Avoid extended periods of continuous flashing, particularly at frequencies of 10 to 20 flashes per second. At flash rates below 5 flashes per second, it is estimated that only 5% of flicker-sensitive persons will be at risk of seizure.

Make sure that personnel at the venue are trained in the care of a person who is having an epileptic seizure and able to provide care if necessary.

If strobes are in use and a person has a seizure, switch the strobes off immediately.

Mount strobes as high above head height as practicable.

---

## **2.2 Warranty conditions**

- 1.** The fixture is under warranty for 36 months from the purchase date against factory defections.
  - 2.** Damage ought to unskillfulness, inappropriate use, or lack of suggested maintenance are excluded from the warranty.
  - 3.** Warranty expires when the projector is opened by unauthorized personnel.
  - 4.** Warranty doesn't include the replacement of the fixture.
  - 5.** Serial number and model of the fixture are necessary to retrieve informations and assistance from the dealer.
- 

## **2.3 EC Norms**

The projector meets all fundamental applicable EC requirements.

# 3. Product specifications



## 3.1 Technical characteristics

<b>Power supply</b>	AC 100-277 V , 50-60 Hz, auto-sensing
<b>Maximum current</b>	1.0 A at 230 V, 2.0 A at 115 V
<b>Power factor</b>	$\text{Cos}\phi = 0.97$ at 230V, $\text{Cos}\phi = 0.99$ at 115V
<b>Max power consumption</b>	225 W
<b>Color temperature</b>	VariWhite LEDs from 2.700 to 6.500 K
<b>Led source</b>	*8 Bridgelux COB Thrive Series (2 x 2700K + 6 x 6500K)
<b>Weight</b>	10.5 Kg / 23.14 lbs (incl.PSU)
<b>Storage temperature</b>	from - 40° C / -40° F to + 80° C / +176° F
<b>Working temperature</b>	from - 25° C / -13° F to + 40° C / +104° F
<b>IP/IK Rating</b>	IP65 - IK10 - Anti-Corrosion treatment for marine ambient
<b>Installation parameters</b>	Maximum installation height: <15m Maximum wind exposure: 90° (0.06M <sub>2</sub> front- 0.04M <sub>2</sub> side) EPA 0.11M <sub>2</sub> Suitable for indoor / outdoor use

\*The COB LED are not replaceable by the user.

## 3.2 Dimensions

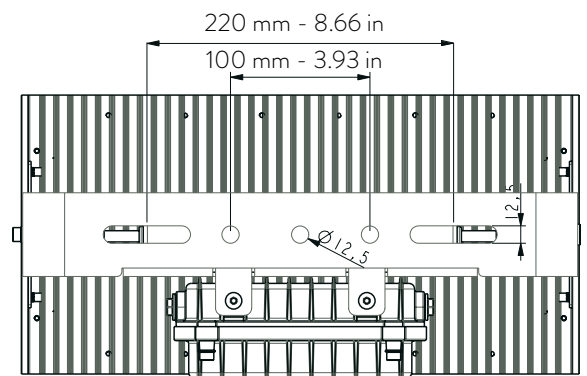
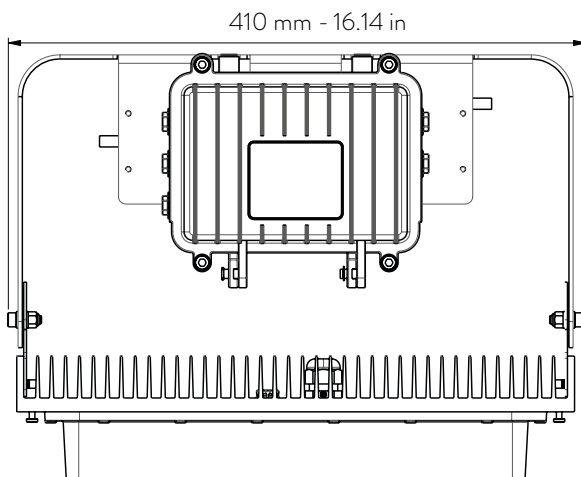
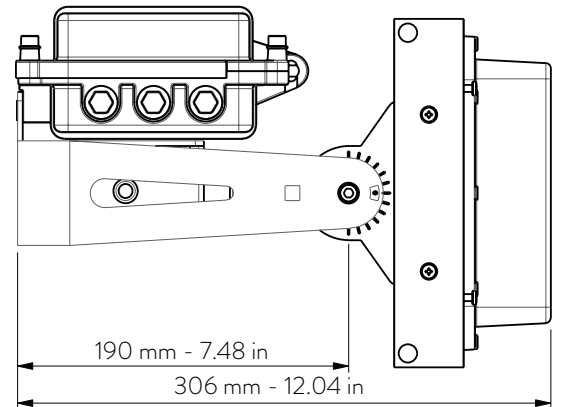
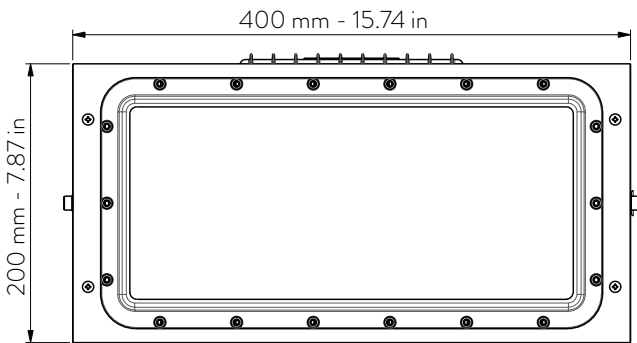

### 3.3 Unit's main components

Pressure equalization valves in the housing equalizes pressure by allowing air to pass through it when the fixture heats up and cools down, but at the same time it acts as a barrier to water in liquid form. The expulsion of warm air (with a slightly higher water vapor content) and intake of cool air (with a slightly lower water vapor content) prevents humidity buildup over time, provided that the valve works correctly and that the fixture is correctly sealed. Valves cannot be cleaned and must be replaced if they become blocked. Valve replacement intervals depend on the amount of dirt and dust in the installation location. We recommend that you consult your Coemar supplier about possible inspection intervals.

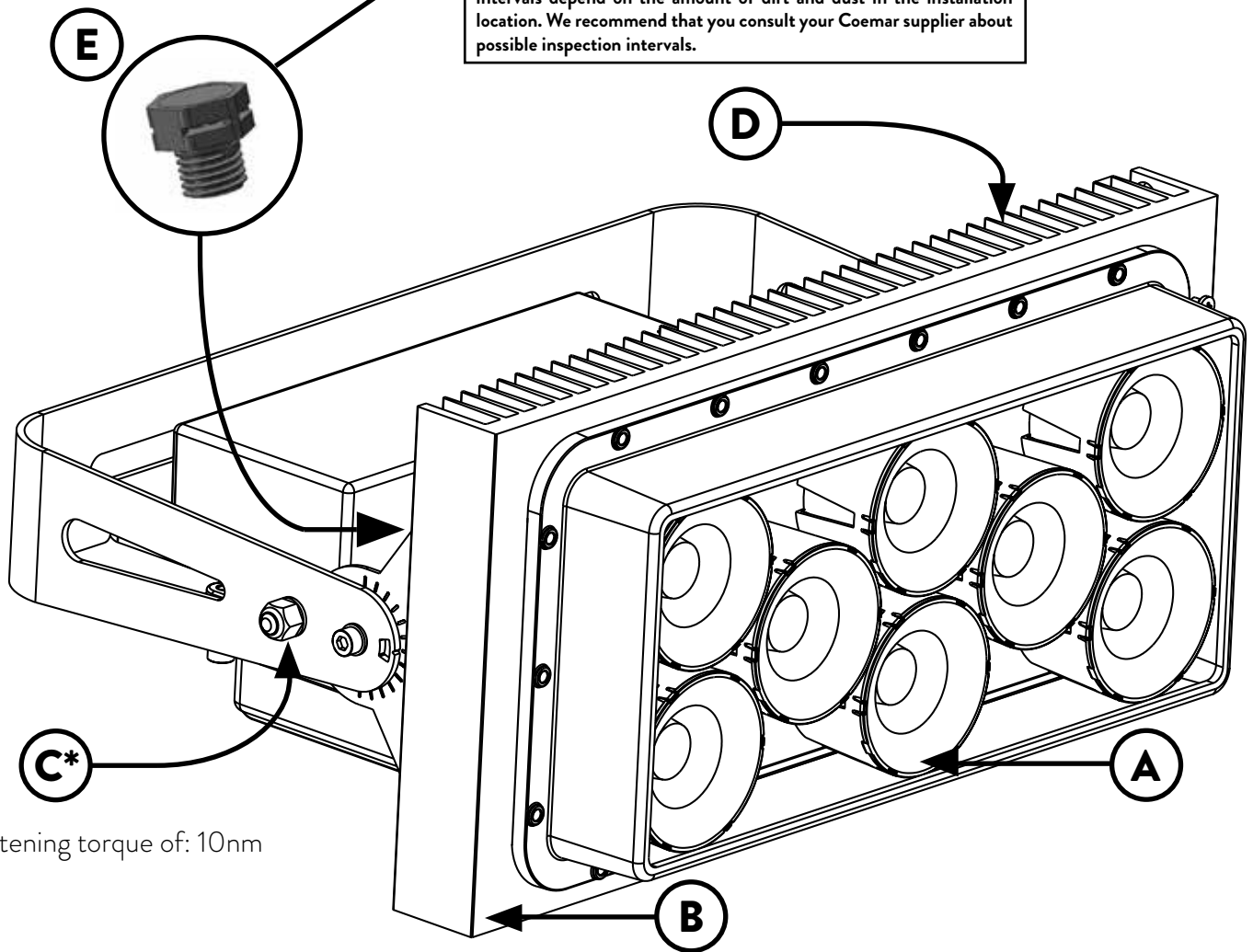

\*Tightening torque of: 10nm



Components description	
<b>A</b>	Optical holder tube
<b>B</b>	Yoke with mounting holes
<b>C</b>	Locking screw for yoke
<b>D</b>	Cooling unit
<b>E</b>	Screw Vent

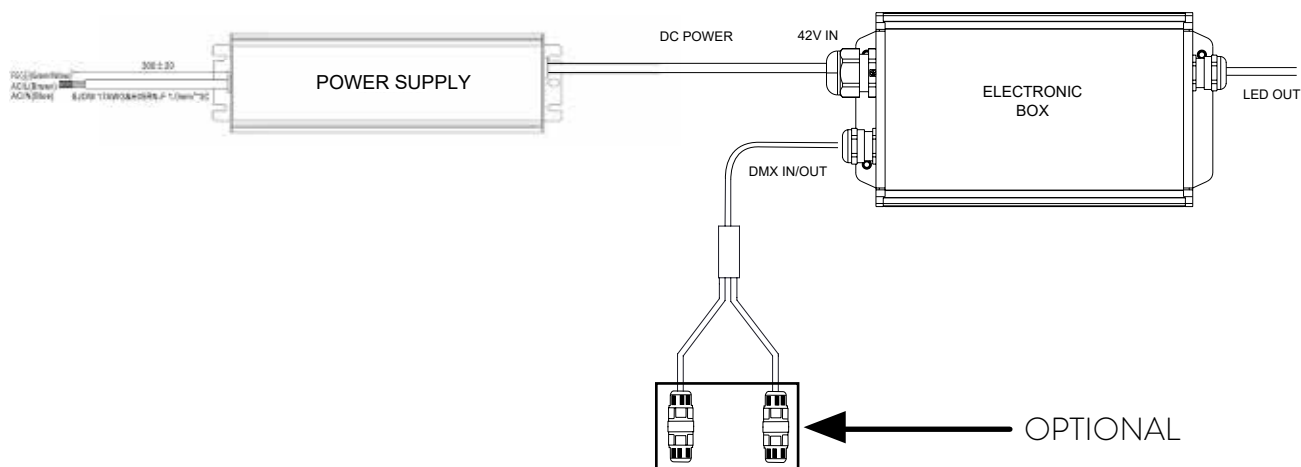

### 3.4 Back panel description

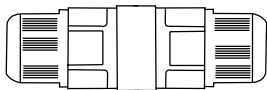
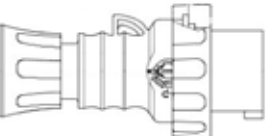

#### Recommended Power Plug Connector (optional)

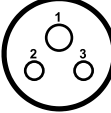
SYMBOL	USE	CONNECTION
	<b>Power Junction Connector for AC</b> Cod Art. RCN 72	<b>E - Green/Yellow</b> <b>AC/L - Brown</b> <b>AC/N - Blue</b>
	<b>Power Connector for AC CEE 16A</b> Cod Art. RME 641/1	<b>Pin 1 = Earth</b>  <b>Pin 2 = L-Brown</b> <b>Pin 3 = N-Blue</b> 

#### Recommended Signal Plug Connector (optional)

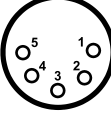
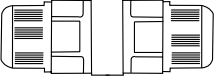
SYMBOL	USE	CONNECTION
	<b>DMX Signal Connector XLR 5</b> <b>MALE (IN)</b> Cod Art. RME 35/2 <b>FEMALE (OUT)</b> Cod Art. RME 34/2	<b>Pin 1 = Ground (Shield)</b> <b>Pin 2 = Data - (Black)</b> <b>Pin 3 = Data + (Red)</b> <b>Pin 4 = Not connected</b> <b>Pin 5 = Not connected</b> 
	<b>DMX Signal Junction Connector</b> Cod Art. RCN 73	<b>DMX 512 STANDARD:</b> <b>Pin 1 = Shield</b> <b>Pin 2 = Data + (Red)</b> <b>Pin 3 = Data - (Black)</b>

# 4. Installation

## 4.1 Mechanical installation

**SunLite LED Series** may be hung from an appropriate structure in any position or on tripod. If hanging the fixture from a lighting truss or similar, we recommend the use of an appropriate clamp “**A**”, as shown in the following diagram.

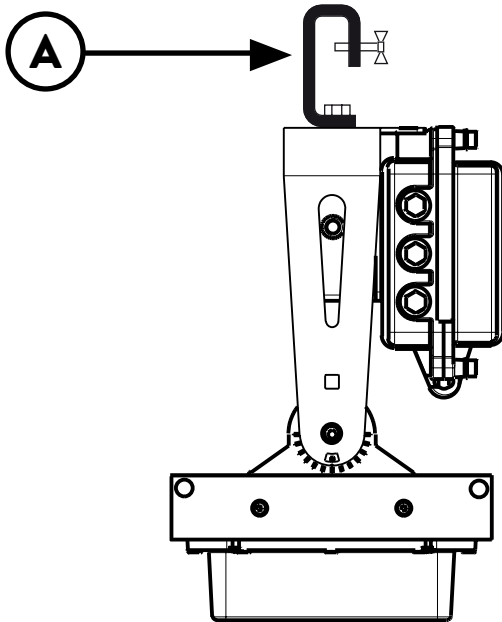

**Warning!!**  
Always ensure that your support structure and fixing (bolts, clamps, etc...) are rated to support the weight of the fixture.

**Warning!!**  
Do not mount the product with the light source facing upwards.

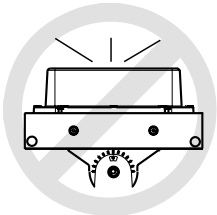

**Warning!!**  
Do not mount the product in a vertical position.

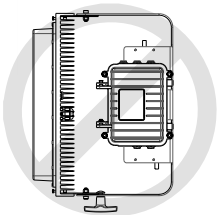

## 4.2 Safety chain

When hanging **SunLite LED Series** it is recommended to use a safety chain, as required by current legislation. The safety chain must pass through the handles of the unit and then attached to the structure. If using steel cables and chains not **Coemar**'s production, make sure they are suitable to support the weight of the unit according to normative UL/ETL.

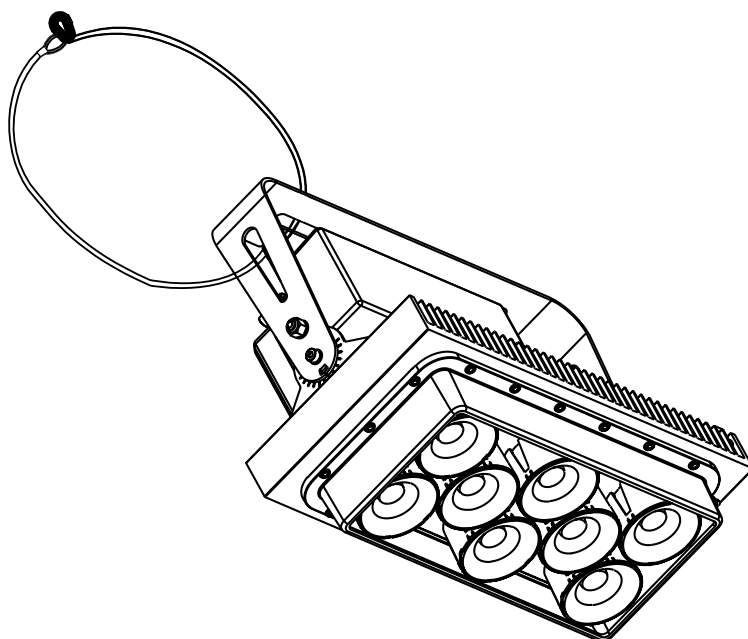

### 4.3 How to change the optical lenses

It is possible to change the optical lenses in order to obtain a different luminous beam angle. Here following you can see all the steps.

Remove all the screws "A" present on the entire perimeter of the Plexiglas, as shown in the drawing, in order to remove the Plexiglas cover.

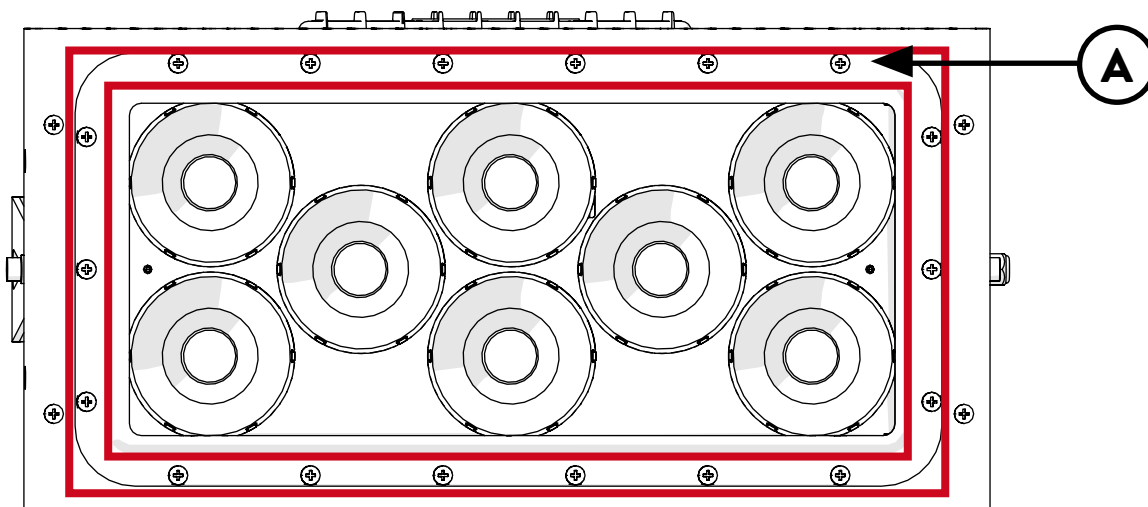

Rotate the lens "B" counterclockwise until it releases from its compartment. Then it will be possible to remove the lens from the holder "C".

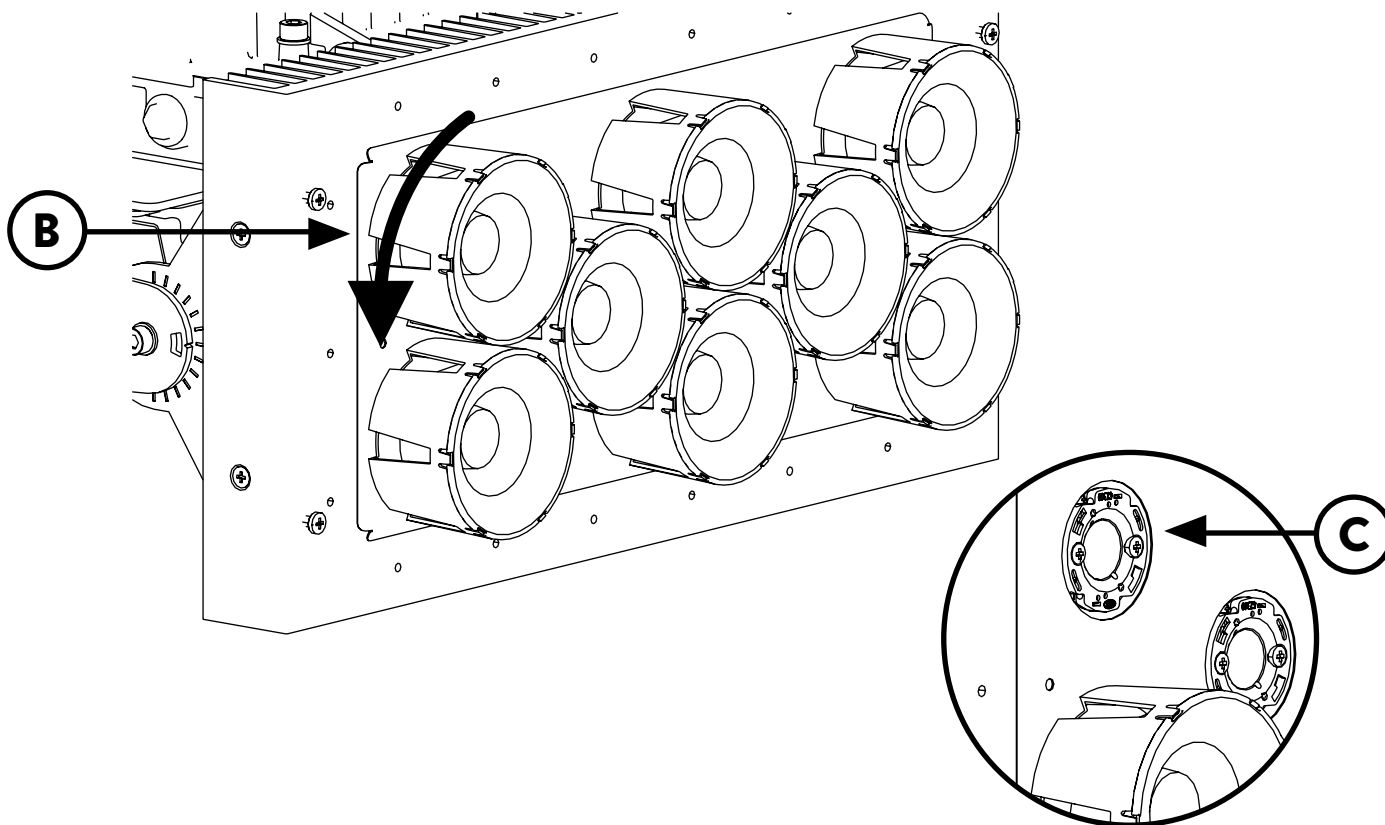

Once this is done, it will now be possible to replace the various lenses with the others you have chosen. Therefore pay attention to the back of the lenses where there are two pins “D”, which must be inserted into their slots “E”.

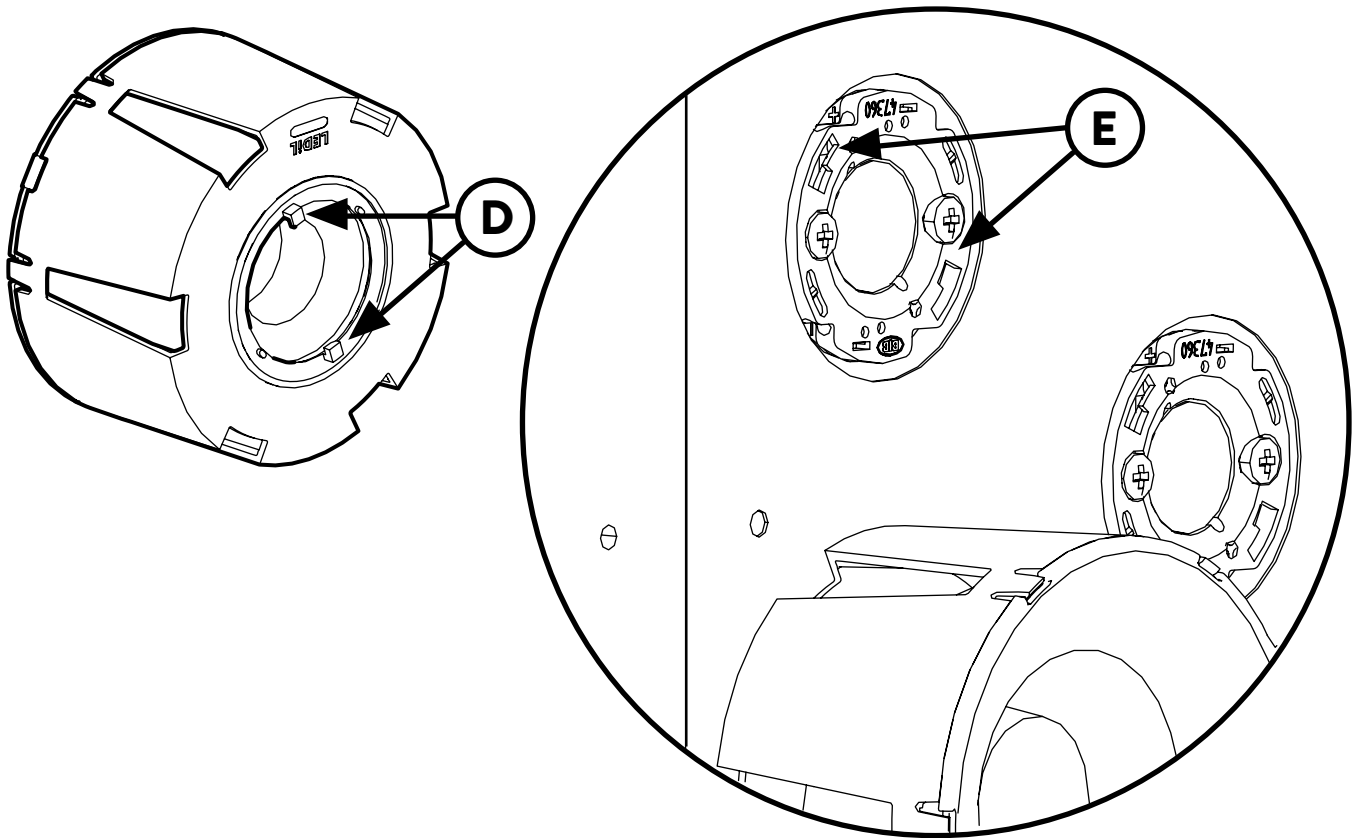

Turn clockwise until the lens is perfectly fitted.

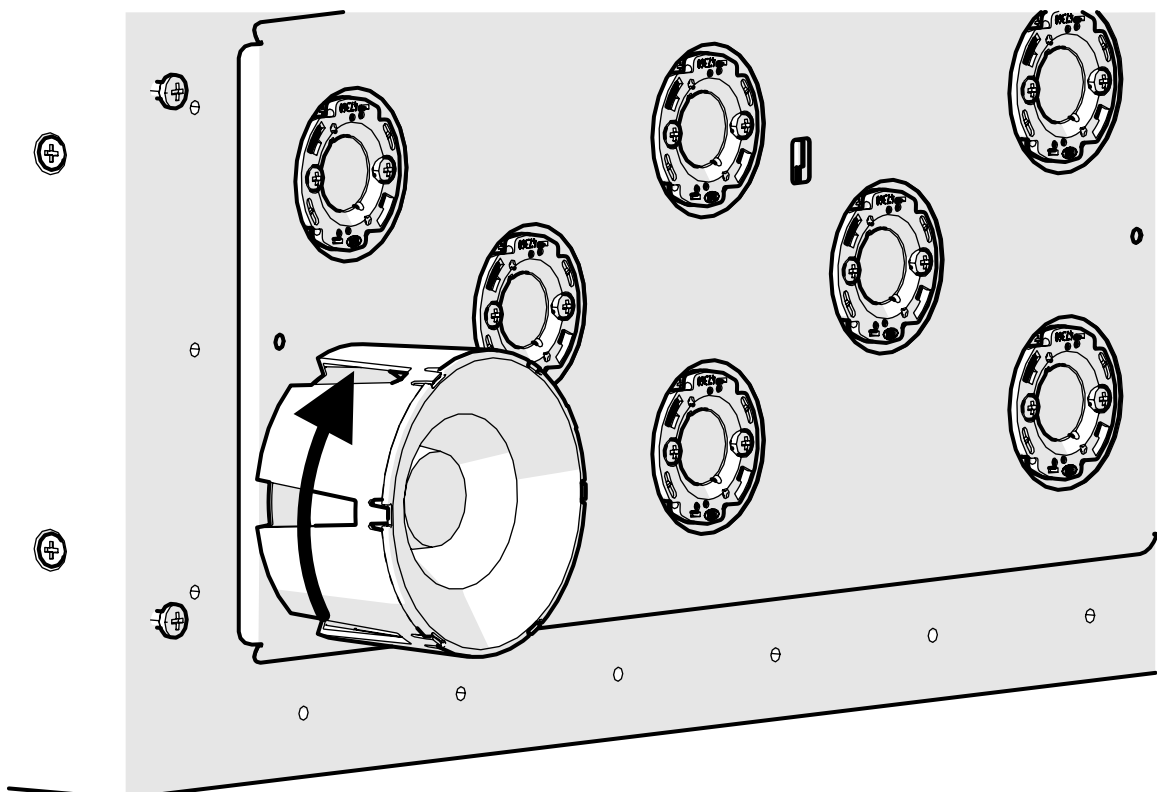

## 4.4 How to mount the Louver

To mount the Louver "A", it is necessary to match it with the Plexiglas cover, once this is done screw the screws "B".

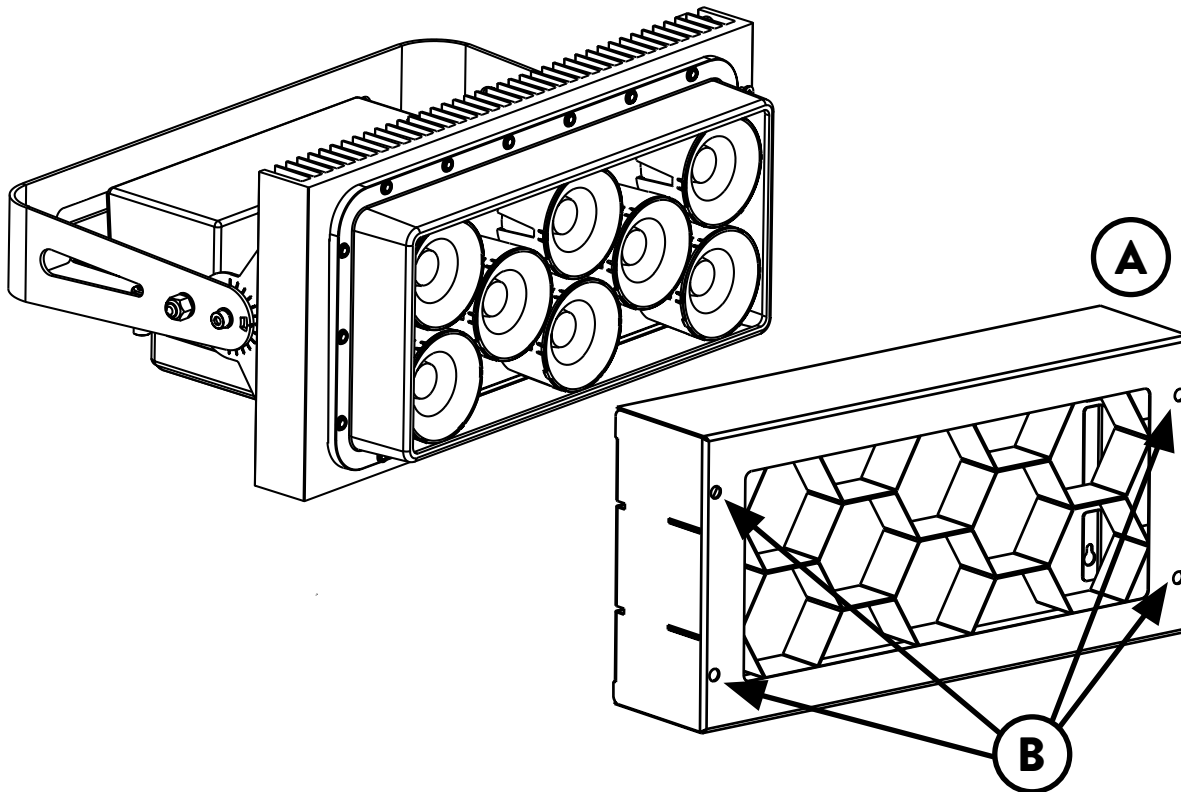

## 5. Powering up



### 5.1 Operating voltage and frequency

The unit may operate at voltage ranges from 100V to 277V at a frequency of 50 or 60 Hz. It is not needed to effect any setup procedures: **SunLite LED Series** will automatically adjust its operation to suit any frequency or voltage within this range.

Power supply protections: **Over current** (Constant current limiting, recovers automatically after fault condition is removed), **Short circuit** (Hiccup mode, recovers automatically after fault condition is removed),

**Over Voltage** (Shut down and latch off o/p voltage, re-power on to recover).

### 5.2 Connection to mains power

#### Mains cable characteristics

The mains cable provided is thermally resistant, complying to the most recent International standards.

**Note:** in case of cable replacement, similar cable with comparable thermal resistant qualities must be used exclusively (cable 3 X 1,5  $\varnothing$  external 10 mm, rated 300/500 V, tested to 2 KV, operating temperature  $-40^{\circ}\text{C} + 180^{\circ}\text{C}$ , Coemar cod. CV5311).

#### Connection to mains power

**SunLite LED Series** is equipped with an internal cable without power plug.

The max absorption of **SunLite LED Series** is reported in the following table:

- 230V - 1.0A constant during normal exercise.
- 115V - 2.0A constant during normal exercise.

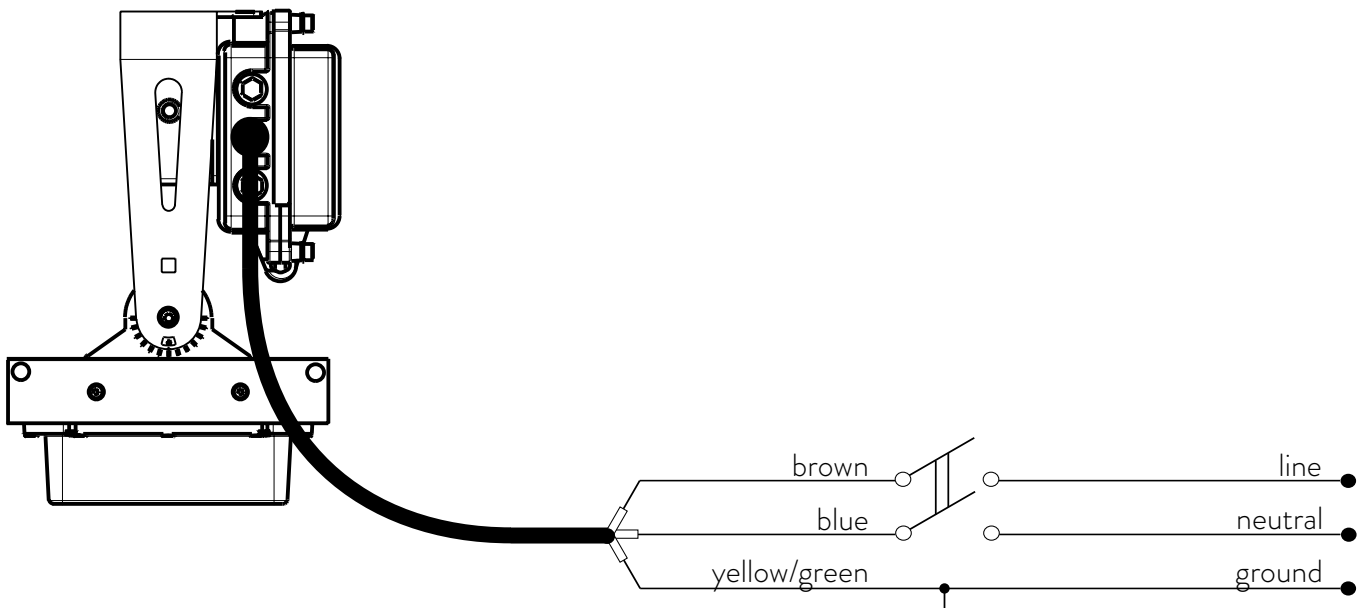

### Warning!!

The use of a thermal/magnetic circuit breaker is recommended. Strict adherence to regulatory norms is strongly recommended.

**SunLite LED Series** should not be powered through a dimmer as this may damage the internal switching power supply.

Prior to connecting the device to mains power, ensure that the mains characteristics are within the recommended range for the use of **SunLite LED Series**.

All cabling and connections should be carried out by a suitably qualified personnel.

## 6. Control signal connections



### 6.1 Control signal connection by XLR5 plugs

The digital control signal is transmitted to the projector via a two pole cable screened as per International standards for the transmission of DMX 512 data. The connection must be serial, using connectors XLR5 male and female located on the back of **SunLite LED Series** labelled DMX512 IN e OUT (see diagram).

Connectors equipped on **SunLite LED Series** are IP rated, which ensures protection against water and dust. In order to keep this rating they must be connected exclusively to other IP rated connectors.

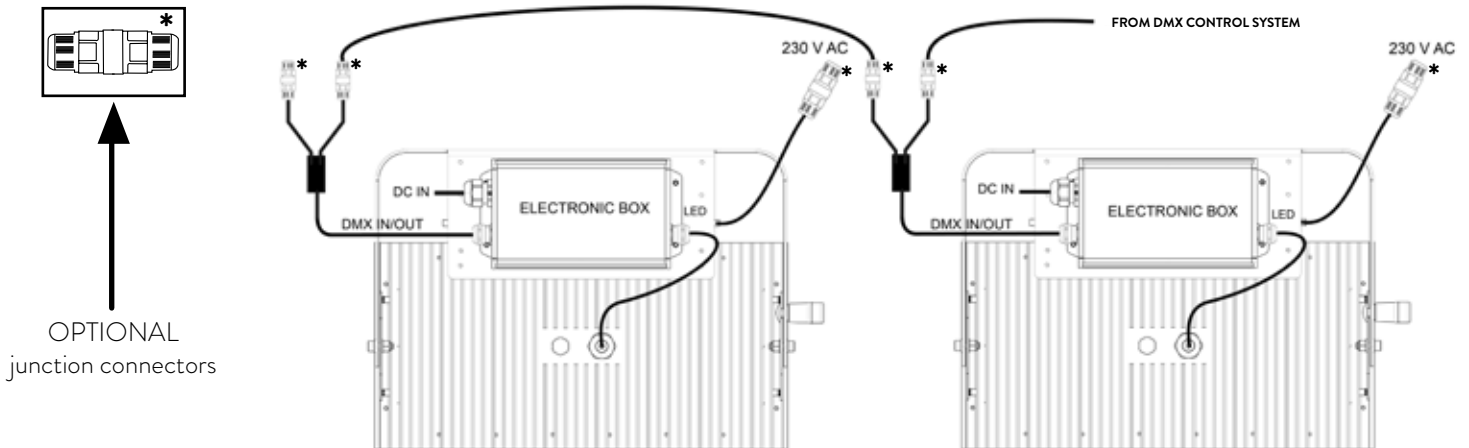

### Warning!

Make sure that screening and conductors are not in contact one another or with the metal housing of the connector.

Pin#1 and housing never must be connected to the power supply unit.

## 7. Turning the projector on



**!The factory setting at the first start up will be in “SUNRISE MODE” at 2000Hz.**

After having followed the preceding steps described, proceed with the power supply and turn on the projector connecting it to the mains power.

## 8. Setup via RDM

### 8.1 Quick guide to menu

The **SunLite LED Series** required RDM (Remote Device Management) to set up fixtures. Using an RDM-compliant DMX controller, you can communicate with all the fixtures on a data link without needing to connect to each fixture individually. RDM lets you set the DMX addresses of all the fixtures on the link, carry out fixture configuration and retrieve fixture data including details of any error that has been logged.

If two or more identical fixtures are set up with the same DMX address and in the same DMX mode, they will receive the same instructions and behave identically. Setting up identical fixtures with the same address is a good tool for troubleshooting unexpected behavior and an easy way to achieve synchronized action.

Setting DMX addresses via RDM involves running a scan to identify the fixtures that are present on the data link and then allocating addresses either automatically or manually.

To use RDM:

1. Obtain an RDM-compatible controller such as the RDM UPGRADE INTERFACE B (cod. AC10011A001) application running on a Windows PC.
2. Use a USB cable to connect the PC to a USB/DMX interface box
3. Connect the interface box to the data link.
4. Power the fixture on and carry out an RDM discovery / scan in your RDM-compatible controller.
5. You can then configure or retrieve data from the fixtures on the data link.

### 8.2 RDM Chart

PARAMETER	DESCRIPTION
DMX ADDRESS	Set Dmx Address: (1-512)
CURVE	Set Dimming Curve: Linear, Logarithmic, Exponential, Halogen
FREQUENCY	Set Pwm Frequency: 600Hz-1500Hz-2000Hz-5000Hz-20.000Hz
LOCK PIN	Set Lock Pin
LOCK STATE	Set Screen Lock
FACTORY DEFAULT	Factory Reset
PERSONALITY	Set Personality: 5Ch, 2Ch, 4Ch, Sunrise Mode
SENSOR	Visualize Sensor
LED HOURS	Visualize Led Life Hours
DEVICE HOURS	Visualize Device Life Hours



### 8.3 RDM Error Chart

<b>ERROR</b>	<b>DESCRIPTION</b>	<b>SOLUTION</b>
MEMORY	Memory Reading Error	Perform A “Factory Reset”
HW MEMORY	Memory Hardware Error	Contact Coemar
DMX ADDR	Dmx Addressing Error	The Personality Dimension Exceeds 512 Channels
NTC ERROR	Temperature Sensor Disconnected	Check Wiring Ntc Led
SHORT NTC	Short-Circuited Temperature Sensor	Check Wiring Ntc Led
OVER TEMP	Electronic Board Overtemperature	Ambient temperature too high, place the projector in an environment with temperature below 40 °C

# 9. DMX chart



## 9.1 DMX Chart 5 channels

channel	function	type of control	effect	decimal	percentage
1	master dimmer	proportional	adjust luminous output intensity from 0 to 100%	0 - 255	0% - 100%
2	dimmer fine	proportional	fine dimmer control 16 bit	0 - 255	0% - 100%
3	white tone	step	2.700 K	0 - 6	0% - 2%
		proportional	proportional value from 2.700 K to 3.200 K	7 - 33	3% - 13%
		step	3.200 K	34 - 60	13% - 24%
		proportional	proportional value from 3.200 K to 4.000 K	61 - 87	24% - 34%
		step	4.000 K	88 - 114	35% - 45%
		proportional	proportional value from 4.000 K to 5.000 K	115 - 141	45% - 55%
		step	5.000 K	142 - 168	56% - 66%
		proportional	proportional value from 5.000 K to 5.600 K	169 - 195	66% - 76%
		step	5.600 K	196 - 222	77% - 87%
		proportional	proportional value from 5.600 K to 6.500 K	223 - 249	87% - 98%
4	strobe effect	step	no effect	0 - 9	0% - 4%
		proportional	variable speed strobing effect, from slow to fast	10 - 57	4% - 22%
		step	stop strobe	58 - 59	23% - 23%
		proportional	sequenced pulse effect, slow closing, fast opening (variable speed pulsing, from slow to fast)	60 - 108	24% - 42%
		step	stop strobe	109 - 110	43% - 43%
		proportional	sequenced pulse effect, fast closing, slow opening (variable speed pulsing, from slow to fast)	111 - 159	44% - 62%
		step	stop strobe	160 - 161	63% - 63%
		proportional	random strobe effect with variable speed from slow to fast	162 - 207	64% - 81%
		step	stop strobe	208 - 209	82% - 82%
5	special functions	step	park	0 - 9	0% - 4%
			600 Hz	10 - 22	4% - 9%
			no effect	23 - 199	9% - 78%
			LED control frequency tuning 1.500 Hz	200 - 205	78% - 80%
			LED control frequency tuning 2.000 Hz	206 - 211	81% - 83%
			LED control frequency tuning 5.000 Hz	212 - 217	83% - 85%
			no effect	218 - 240	85% - 94%
			LED control frequency tuning 20.000 Hz	241 - 255	95% - 100%
<b>Projector:</b> SunLite LED Series			<b>Chart name:</b> DMX512 function		<b>software version:</b> 0.039
<b>Edition:</b> 2			<b>Date:</b> 30.05.2022		

## 9.2 DMX Chart (2/1 ch)

channel		function	type of control	effect	decimal		percentage	
2	1							
1	1	master dimmer	proportional	adjust luminous output intensity from 0 to 100%	0	-	255	0% - 100%
2	-	white tone	proportional	proportional value from 2.700 K to 6.500 K	0	-	255	0% - 100%
<b>Projector:</b> SunLite LED Series				<b>Chart name:</b> DMX512 function		<b>software version:</b> 0.039		
<b>Edition:</b> 2				<b>Date:</b> 30.05.2022				

## 9.3 DMX Chart (SUNRISE mode)

channel	function	type of control	effect	decimal	percentage
1	master dimmer	proportional	adjust luminous output intensity from 0 to 100%	0 - 255	0% - 100%
2	dimmer fine	proportional	fine dimmer control 16 bit	0 - 255	0% - 100%
3	proportional cct	proportional	2.700 K	0	0%
			proportional value from 2.700 K to 4000 K	1 - 86	0% - 34%
			4.000 K	87	34%
			proportional value from 4.000 to 5.000 K	88 - 152	35% - 60%
			5.000K	153	60%
			proportional value from 5.000 to 5.600 K	154 - 192	60% - 75%
			5.600K	193	76%
			proportional value from 5.600 K to 6.500 K	194 - 254	76% - 100%
6.500 K	255	100%			
4	step cct	step	no effect	0 - 9	0% - 4%
			2.700 K	10 - 50	4% - 20%
			3.200K	51 - 91	20% - 36%
			4.000K	92 - 132	36% - 52%
			5.000K	133 - 173	52% - 68%
			5.600K	174 - 213	68% - 84%
			6.500K	214 - 255	84% - 100%
5	special functions	step	park	0 - 9	0% - 4%
			600 Hz	10 - 22	4% - 9%
			no effect	23 - 199	9% - 78%
			LED control frequency tuning 1.500 Hz	200 - 205	78% - 80%
			LED control frequency tuning 2.000 Hz	206 - 211	81% - 83%
			LED control frequency tuning 5.000 Hz	212 - 217	83% - 85%
			no effect	218 - 240	85% - 94%
			LED control frequency tuning 20.000 Hz	241 - 255	95% - 100%

**Note 1:** If channels 3 and 4 are used simultaneously, channel 4 prevails.

**Projector:** SunLite LED Series

**Chart name:** DMX512 function

**software version:** 0.039

**Edition:** 2

**Date:** 30.05.2022

## 9.4 DMX Chart (RAW mode)

channel	function	type of control	effect	decimal	percentage
1	warm white led	proportional	adjust luminous output intensity of warm white led from 0 to 100%	0 - 255	0% - 100%
2	warm white led fine	proportional	warm white led fine control 16 bit	0 - 255	0% - 100%
3	cold white led	proportional	adjust luminous output intensity of cold white led from 0 to 100%	0 - 255	0% - 100%
4	cold white led fine	proportional	cold white led fine control 16 bit	0 - 255	0% - 100%
<b>Projector:</b> SunLite LED Series			<b>Chart name:</b> DMX512 function		<b>software version:</b> 0.039
<b>Edition:</b> 2			<b>Date:</b> 30.05.2022		

# 10. Accessories and spare parts



All the components of **SunLite LED Series** are available as spare parts from your **Coemar** dealer or Service. Accurate description of the fixture, model number and type will assist us in providing for your requirements in an efficient and effective manner.

Code	Description	Code	Description
F073G001H	Narrow Lenses, Black	RCN 72	Power Junction Connector for AC
F073G001I	Medium Lenses, Black	RME 641/1	Power Plug CEE 16A
F073G001L	Wide Lenses, Black	RME 34/2	DMX Signal Connector XLR5 Female (OUT)
F073G001O	Ultrawide Lenses, Black	RME 35/2	DMX Signal Connector XLR5 Male (IN)
F073G101H	Narrow Lenses, Silver	RCN 73	DMX Signal Junction Connector
F073G101I	Medium Lenses, Silver		
F073G101L	Wide Lenses, Silver		
F073G101O	Ultrawide Lenses, Silver		
O336.045	Louver (Protection Grid)		

# 11. Maintenance



## 11.1 Firmware update

The firmware of **SunLite LED Series** can be updated through the RDM protocol (ANSI E1.20). Contact **Coemar** assistance to receive the software and the device updater.

## 11.2 Periodic cleaning

**!Regular cleaning is essential for fixture life and performance.**

**Buildup of dust and dirt degrades the fixture's light output and cooling ability.**

**!To clean the housing and front cover isolate the fixture from AC power and allow the fixture to cool for 20 minutes.**

**!Before closing the cover after each cleaning, remember to heat the LEDs for at least 20 minutes, so as to eliminate all traces of humidity.**

### Lenses

Even a thin layer of dust can reduce the luminous output and alter the consistency of the beam. Regularly clean all filters and lenses using a soft cotton cloth, dampened with a special lens cleaning solution.

### Cleaning of the unit

Use a soft brush or a common vacuum cleaner or a source of compressed air for removing dust.

For the cleaning of the housing use a soft cloth and a non-aggressive cleaner, Lukewarm Water or Mild Soap. **FORBIDDEN:** (Abrasive Cleaners, Highly Alkaline Cleaners, Aromatic Solvents, Halogenated Solvents, Brushes, Steel Wood).

Check that the internal fans (if provided in the product) and heat exchanger must be perfectly clean.

Don't use pressure washer or water jet, do not leave cleaners on plastic parts for a long period and do not apply cleaners in direct sunlight or at elevated temperatures.

## 11.3 Periodic controls

### Mechanical components

Check the correct working of the mechanical parts and, if needed, replace them. Make sure the projector is not mechanically damaged. If necessary, replace the worn parts.

### Electrical components

Check all electrical connections, in particular for correct grounding and correct attachment of all extractable connectors. Press the connectors if necessary and reposition as before.

---

## 11.4 Fuses

**SunLite LED Series** has an automatic fuse that in most cases does not need to be replaced.

# 12. F.A.Q. and answers



The following list shows common issues that may be simply solved. If issues persist, the unit must be repaired by a qualified personnel or just contact your **Coemar** service.

Question	Possible solution
<b>SunLite LED Series</b> does not emit light	<b>Projector not powered on:</b> <ul style="list-style-type: none"><li>• Make sure the power cable is plugged in or test the input voltage;</li></ul> <b>Wrong DMX address:</b> <ul style="list-style-type: none"><li>• Check the DMX Address setting and the output signal of the controller;</li></ul>
<b>SunLite LED Series</b> is not responding to DMX signal	<b>DMX signal may not reach SunLite LED Series:</b> <ul style="list-style-type: none"><li>• Inspect the cable connection, correct poor connections or inefficient repair or replace damaged cables;</li><li>• Check DMX address of the unit;</li></ul>

# User notes



A series of horizontal dotted lines for writing notes, spanning the width of the page.





**Information on disposal of the equipment**

The equipment at the end of its useful life must be disposed of at an appropriate recycling center for waste electrical and electronic equipment. The treatment and disposal of environmentally friendly, helps prevent potential negative environmental and health and promote the reuse and / or recycling of materials making up the equipment. Illegal disposal by the user includes the application of administrative sanctions provided by law.



**Coemar Lighting s.r.l.**

Via Carpenedolo 90  
46043 Castiglione delle Stiviere, Mantova, Italy  
phone. +39 0376/1514412 - fax +39 0376/1514380  
[info@coemar.com](mailto:info@coemar.com)

**Coemar** reserves the right to change specifications without prior notice