

LEDKO™

DIM T/D

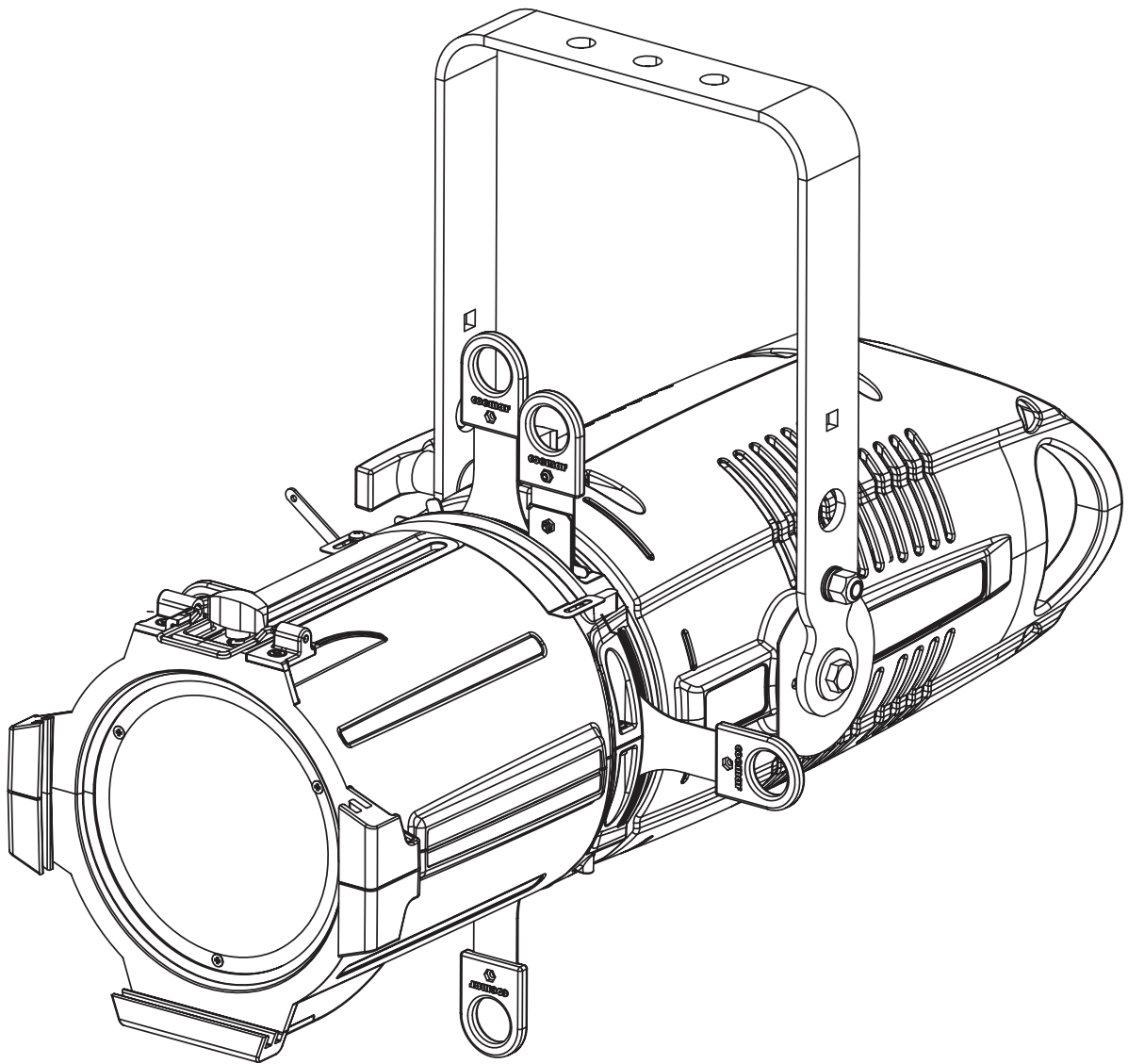

USER MANUAL
vrs. 2.4 - 10.05.2023



© 2023 Coemar Lighting Srl. All rights reserved.

Information subject to change without notice. Coemar and all affiliated companies disclaim liability for any injury, damage, direct or indirect loss, consequential or economic loss or any other loss occasioned by the use of, inability to use or reliance on the information contained in this document. The Coemar logo, the Coemar name and all other trade-marks in this document pertaining to services or products by Coemar or its affiliates and subsidiaries are trademarks or licensed by Coemar or its affiliates or subsidiaries.

No part of this document may be used for distribution, reproduction, transmission, transcription, storage in a data retrieval system, or translated into any language in any form by any means without the prior written permission of Coemar ®. If you are downloading files from our web pages for your personal use, make sure to check for updated versions. Coemar ® cannot take any liability whatsoever for downloaded files, as technical data are subject to change without notice.

Index

1. Packaging and transportation	Pag. 5
1.1. Packaging	Pag. 5
1.2. Transportation	Pag. 5
2. General information	Pag. 5
2.1 Safety informations	Pag. 5
2.2 Warranty conditions	Pag. 6
2.3 EC Norms	Pag. 6
3. Product specifications	Pag. 7
3.1 Technical characteristics	Pag. 7
3.2 Dimensions	Pag. 7
3.3 Weights and dimensions of the projector with various optics	Pag. 8
3.4 Unit's main components	Pag. 9
3.5 Back panel description	Pag. 10
4. Installation	Pag. 11
4.1 Optical Installation	Pag. 11
4.2 Mechanical installation	Pag. 12
4.3 Safety chain	Pag. 12
4.4 Adjusting unit's tilt	Pag. 12
5. Powering up	Pag. 13
5.1 Operating voltage and frequency	Pag. 13
5.2 Connection to mains power	Pag. 13
6. Control signal connections	Pag. 14
6.1 Control signal connection by XLR5 plugs	Pag. 14
7. Turning the projector on	Pag. 15
7.1 DMX address of the unit	Pag. 15
8. DMX Chart	Pag. 16
8.1 DMX mode	Pag. 16
8.2 DMX Chart: 5 and 1 channels	Pag. 17
9. Setup via RDM	Pag. 18
9.1 Quick guide to menu	Pag. 18
9.2 RDM Chart	Pag. 18
9.3 RDM Error Chart	Pag. 19

10. Display panel functions	Pag. 20
10.1 Quick guide to menu	Pag. 20
10.2 Rapid count	Pag. 20
10.3 Main functions menu.....	Pag. 21
10.4 Measures menu (MEAS)	Pag. 23
10.5 Special functions of the fixture	Pag. 25
10.6 Error messages	Pag. 25
11. Accessories and spare parts	Pag. 26
12. Maintenance	Pag. 28
12.1 Firmware update.....	Pag. 28
12.2 Periodic cleaning.....	Pag. 28
12.3 Periodic controls.....	Pag. 28
12.4 Fuses.....	Pag. 28
13. F.A.Q. and answers	Pag. 29

Congratulations on having purchased a **Coemar** product. You have assured yourself of a fixture of the highest quality, both in componentry and in the technology used. We renew our invitation to you to complete the service information on the previous page, to expedite any request for service information or spares (in case of problems encountered either during, or subsequent to, installation). This information will assist in providing prompt and accurate advice from your **Coemar** service centre. Following the instructions and procedures outlined in this manual will ensure the maximum efficiency of this product for years to come.

1. Packaging and transportation

1.1 Packaging

Open the packaging and make sure that no part of the equipment has suffered any damage during the transportation. In case of damage to the fixture, contact your carrier and your supplier immediately by telephone, fax or email, and inform them you will formally notify them in writing through registered letter.

Packing list

Ensure the packaging contains:

- 1 LEDko DIM**
- 1 Instruction manual**
- 1 Main power plugs**

1.2 Transportation

The **LEDko T/D DIM** should be transported in either its original packaging or in an appropriate flight case.

2. General information

2.1 Safety informations

Fire prevention:



1. Never locate the fixture on any flammable surface.
2. Minimum distance from flammable materials: 0,5 m.
3. Minimum distance from the closet illuminable surface: 0,5 m.
4. Replace any blown or damaged fuse only with those of identical values. Refer to the schematic diagram if there is any doubt.
5. Connect the projector to mains power protected by a thermal magnetic circuit breaker.

Prevention from electric shock:



1. Presence of high voltage inside of the fixture. Insulate the projector from mains supply before opening or performing any function which involves touching the inside of the fixture, including lamp replacement.
2. For the connection to the mains, adhere strictly to the guidelines outlined in this manual.

3. The level of technology of **LEDko T/D DIM** requires the use of specialised personnel for all service applications; refer all work to your authorised **Coemar** service centre.
4. A good earth connection is essential for the proper functioning of the projector. Never connect the fixture if there is no earth connection.
5. Mains cables must not come into contact with other cables.
6. Do not operate the projector with wet hands or in an area where water is present.
7. The fixture must never be located in an exposed position, or in areas of extreme humidity.

Safety:



1. The projector must always be installed with bolts, clamps, or other fixing devices which are suitably rated to support the weight of the projector.
2. Always use a secondary safety fixing device with chain or steel wire of a suitable rating to sustain the weight of the unit in case of failure of the principal fixing point.
3. The external surfaces of the unit, at various points, may reach 60°C. Never handle the unit until at least 10 minutes have elapsed since the LED was turned off.
4. Never install the fixture in an enclosed area lacking sufficient air flow; the room temperature must not exceed 40°C.
5. The projector contains electronic and electrical components which must under no circumstances be in contact with water, oil or any other liquid. Failure to do so will compromise the proper functioning of the projector.

2.2 Warranty conditions

1. The fixture is under warranty for 24 months from the purchase date against factory defections.
2. Damage ought to unskillfulness, inappropriate use, or lack of suggested maintenance are excluded from the warranty.
3. Warranty expires when the projector is opened by unauthorized personnel.
4. Warranty doesn't include the replacement of the fixture.
5. Serial number and model of the fixture are necessary to retrieve informations and assistance from the dealer.

2.3 EC Norms

1. The fixture satisfies the essential requirements of the directive 2004/108/EC, 2006/95/EC, 2011/65/EC, 2002/96/EC & 2003/108/EC.
2. The fixture is in accordance with the standard EN 50419 (RoHS) and satisfies the requirements of the directive 2002/96/EC (WEEE).

3. Product specifications

3.1 Technical characteristics

Power supply	90-230 V, auto-sensing, 50/60 Hz
Maximum current	0.86 A at 230 V, 1.76 A at 115 V
Power factor	$\text{Cos}\varphi = 0.99$
Max power consumption	200 W
Color temperature	Tungsten: 3.200 K - Daylight: 5.600 K
Color Rendering Index (CRI)	D and T models: CRI 80, CRI 90
Weight (without optic)	6 kg - 13.2 lbs
Maximum ambient temperature	+35°C / +95°F
IP rating	20

3.2 Dimensions

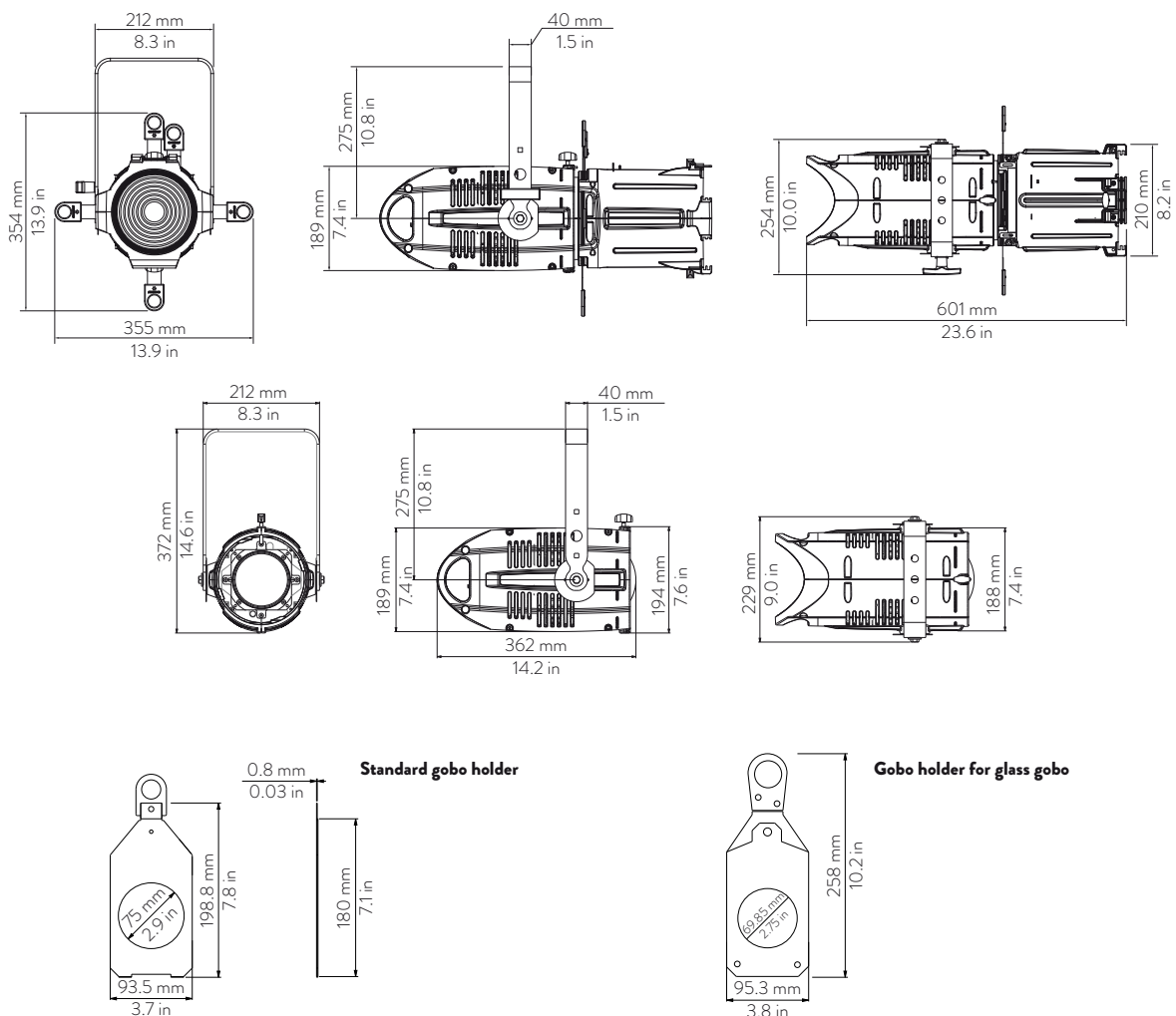

* with Soft Profile Fresnel optic

3.3 Weights and dimensions of the projector with various optics

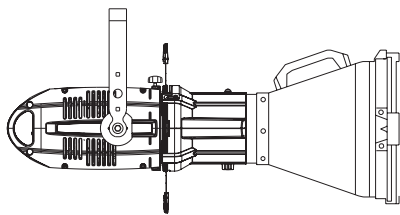

Optics

Lens Tube Profile 10°

Length

900 mm (35.4 in)

Weight

9 Kg (19.8 lbs)

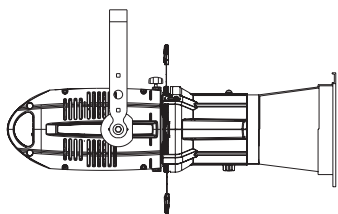

Optics

Lens Tube Profile 14°

Length

750 mm (35.4 in)

Weight

9 Kg (19.8 lbs)

Lens Tube Profile 70°

750 mm (35.4 in)

8.68 Kg (19.14 lbs)

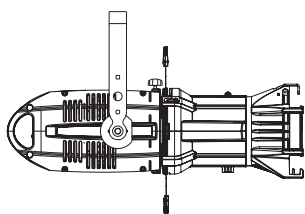

Optics

Lens Tube Profile 19°

Length

670 mm (26.3 in)

Weight

9.15 Kg (20.17 lbs)

Lens Tube Profile 26°

670 mm (26.3 in)

9.05 Kg (19.95 lbs)

Lens Tube Profile 36°

670 mm (26.3 in)

9.35 Kg (20.60 lbs)

Lens Tube Profile 50°

670 mm (26.3 in)

9.05 Kg (19.95 lbs)

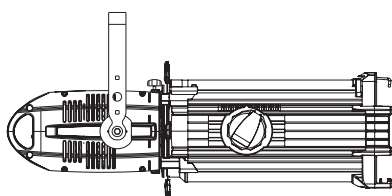

Optics

Profile Zoom 15°-35°

Length

886 mm (34.9 in)

Weight

13.05 Kg (28.77 lbs)

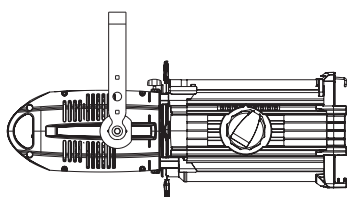

Optics

Profile Zoom 25°-50°

Length

783 mm (30.8 in)

Weight

11.2 Kg (24.69 lbs)

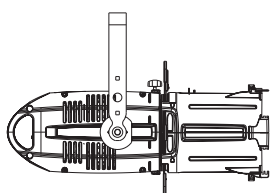

Optics

Profile Zoom 28°-40°

Length

601 mm (23.7 in)

Weight

8.3 Kg (18.3 lbs)

Soft Profile Fresnel

601 mm (23.7 in)

7.75 Kg (17.09 lbs)

Zoom 14°-40°

Soft Profile PC

601 mm (23.7 in)

8.25 Kg (18.19 lbs)

Zoom 11°-38°

3.4 Unit's main components

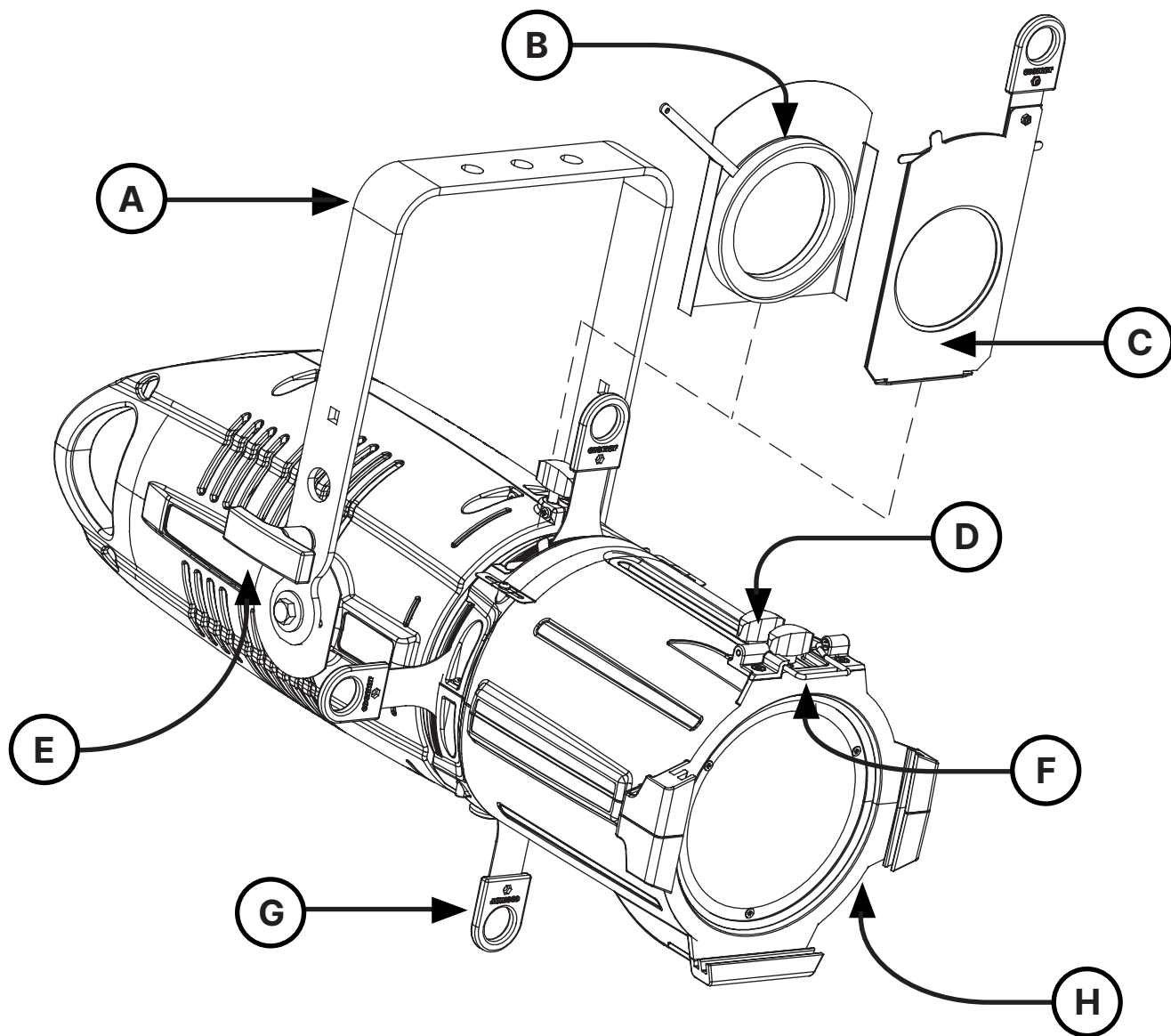

Components description	
A	Adjustable yoke
B	Iris (optional)
C	Gobo holder (optional)
D	Lens adjusting handles
E	Yoke locking handle
F	Gel frame locking spring
G	Profile blade
H	Interchangeable optic

3.5 Back panel description

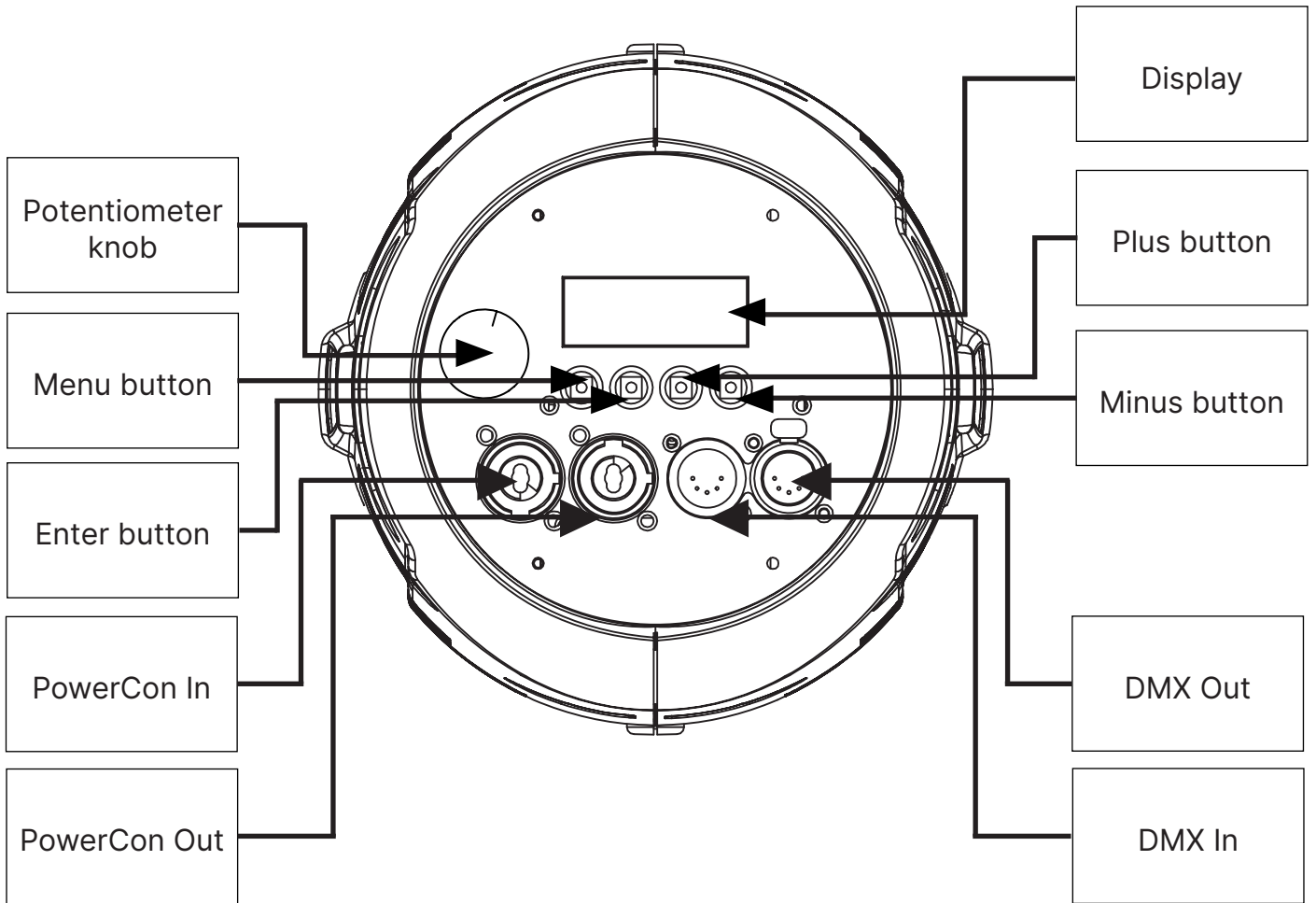

4. Installation

4.1 Optical installation

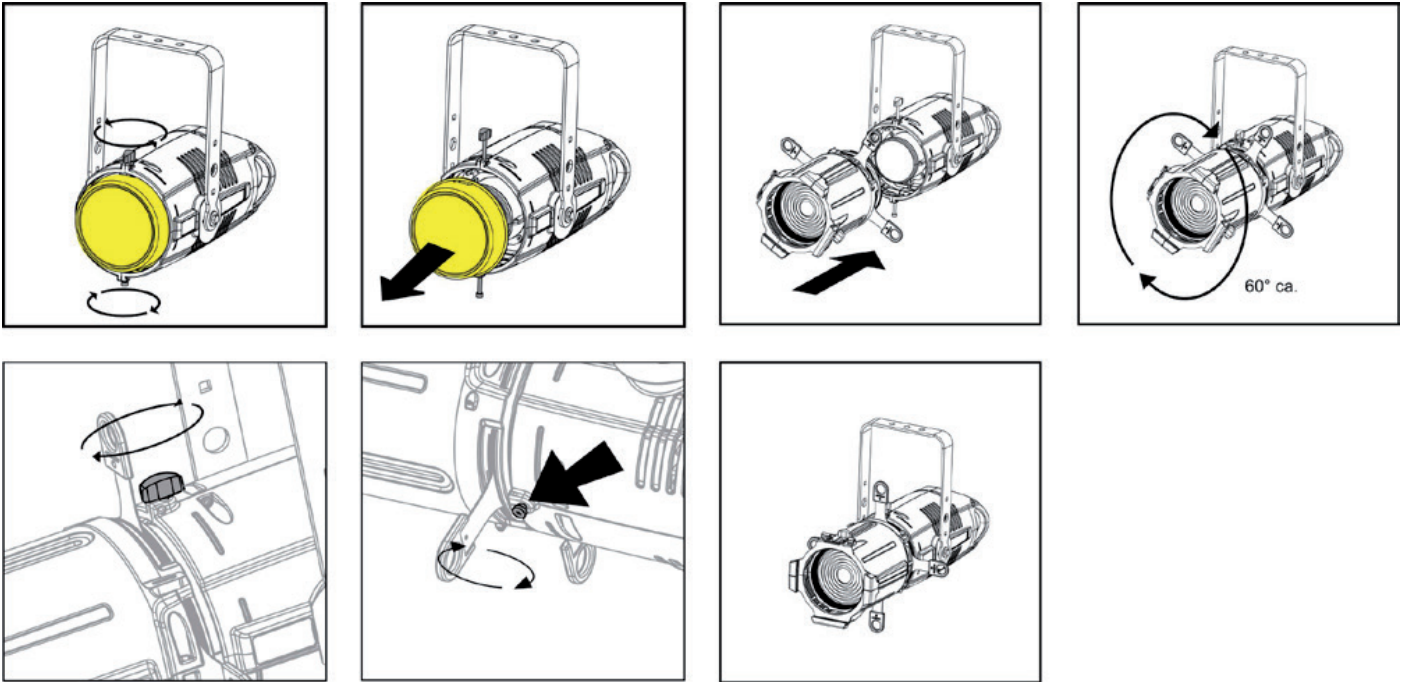

Remove the frontal cap by loosening the upper and lower screws enough to free the cap itself, set the optic's flange tilted about 60°. Insert the optic's flange into the body's receptacle and turn the optic 60° until it is firmly assembled to the projector body, free to rotate but not free to detach itself from the body. Ensure the optic to the body by tightening the two screws previously loosened.

Warning!!

When the protective cap is removed, never lean the fixture facing down.
The front lens can be seriously damaged.

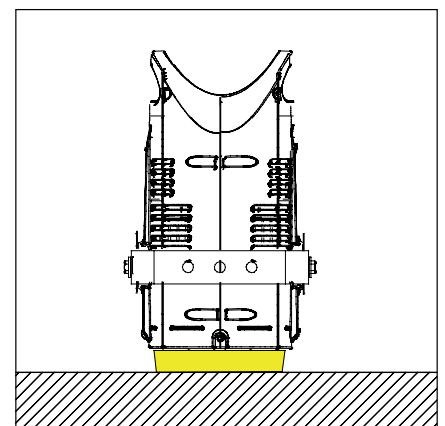
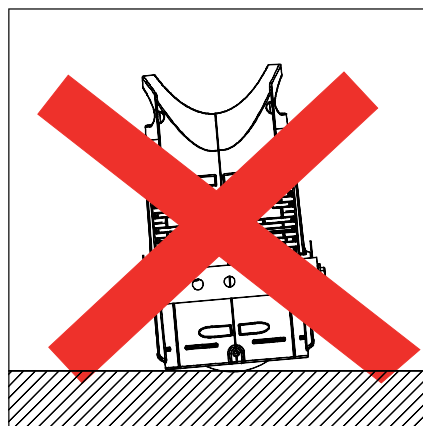
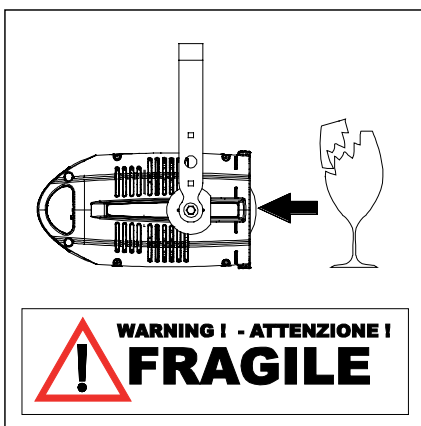

4.2 Mechanical installation

LEDko T/D DIM may be hung from an appropriate structure in any position or on tripod. If hanging the fixture from a lighting truss or similar, we recommend the use of an appropriate clamp "A", as shown in the following diagram.

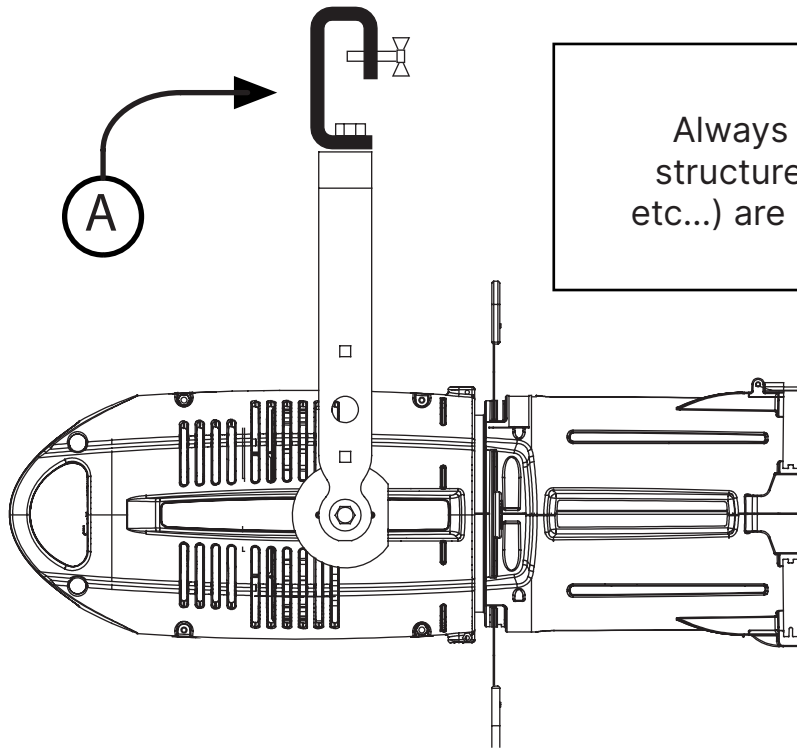

Warning!!

Always ensure that your support structure and fixing (bolts, clamps, etc...) are rated to support the weight of the fixture.

4.3 Safety chain

When hanging **LEDko T/D DIM** it is recommended to use a safety chain, as required by current legislation. The safety chain must pass through the handles of the unit and then attached to the structure.

If using steel cables and chains not **Coemar's** production, make sure they are suitable to support the weight of the unit according to normative UL/ETL (required: the weight of 6 complete devices for at least one hour).

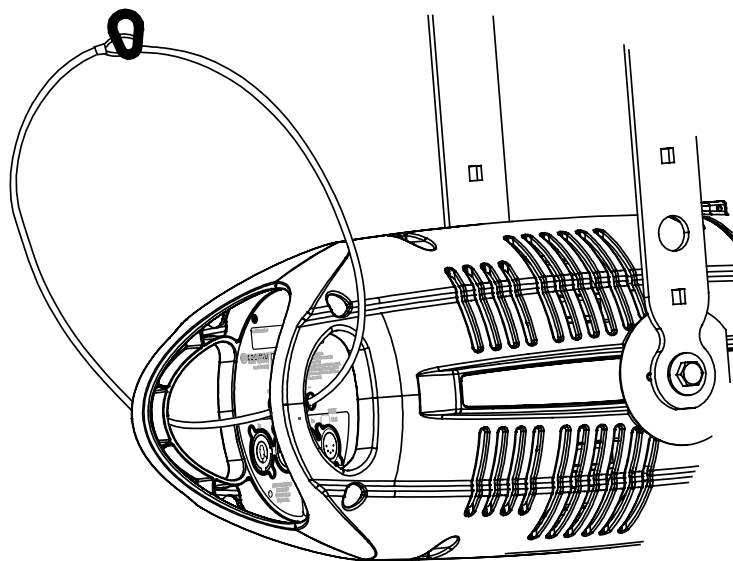

4.4 Adjusting unit's tilt

In order to adjust the tilt of the unit simply loose the side handle adjust the tilt and lock the yoke by tightening the handle again.

5. Powering up

5.1 Operating voltage and frequency

The unit may operate at voltage ranges from 90 to 230 V at a frequency of 50 or 60 Hz. It is not needed to effect any setup procedures: **LEDko T/D DIM** will automatically adjust its operation to suit any frequency or voltage within this range.

5.2 Connection to mains power

Mains cable characteristics

The mains cable provided is thermally resistant, complying to the most recent International standards. Once the fixture is connected to mains power, use the potentiometer knob to dimmer the fixture.

Note: in case of cable replacement, similar cable with comparable thermal resistant qualities must be used exclusively (cable 3 X 1,5 \varnothing external 10 mm, rated 300/500V, tested to 2 KV, operating temperature -40°C + 180°C, Coemar cod. CV5311).

Connection to mains power

LEDko T/D DIM is equipped with two power connectors, one as input and one as output, which can be used to feed up to 8 (at 230 V) or 4 (at 115 V) fixtures.

The max absorption of **LEDko T/D DIM** is reported in the following table:

- 230 V 0.86 A constant during normal exercise.
- 115 V 1.76 A constant during normal exercise.

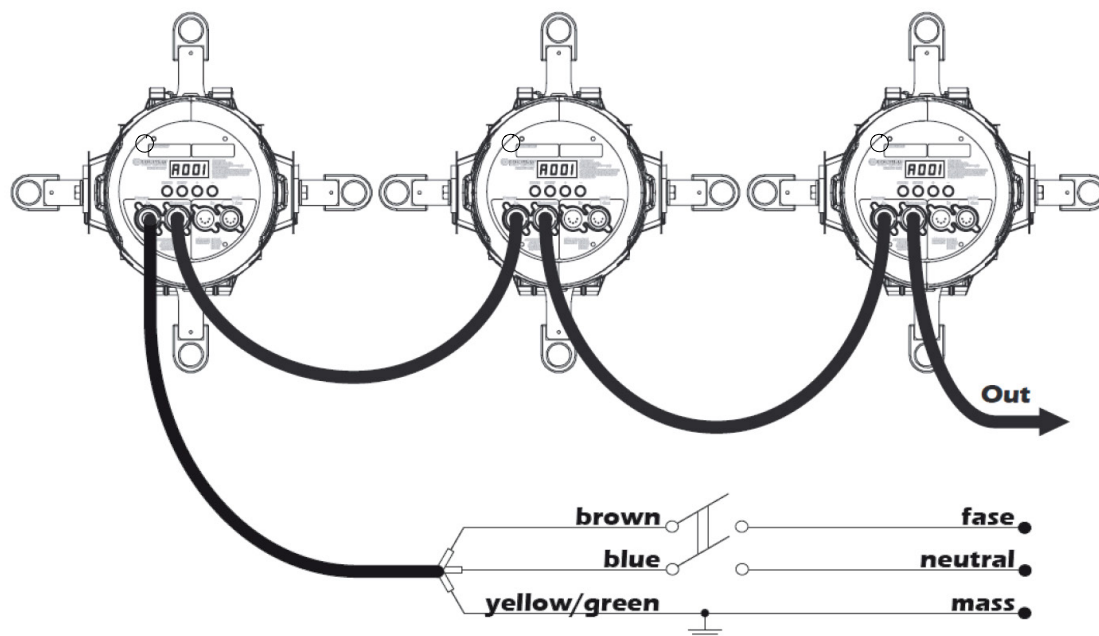

Warning!!

The use of a thermal/magnetic circuit breaker is recommended. Strict adherence to regulatory norms is strongly recommended.

Prior to connecting the device to mains power, ensure that the mains characteristics are within the recommended range for the use of **LEDko T/D DIM**.

All cabling and connections should be carried out by a suitably qualified personnel.

6. Control signal connections

6.1 Control signal connection by XLR5 plugs

The digital control signal is transmitted to the projector via a two pole cable screened in according to the International standards for DMX 512 data transmission. The connection must be serial, using connectors XLR5 male and female located on the back of **LEDko T/D DIM** labelled DMX512 IN e OUT.

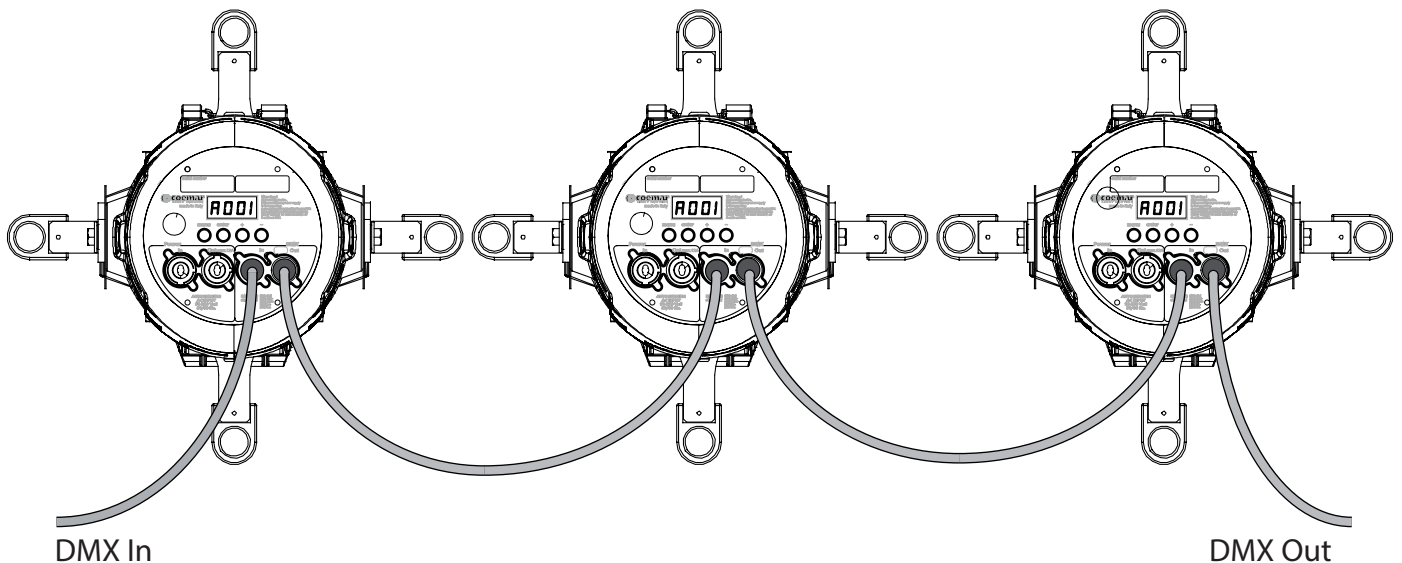

Warning!

Make sure that screening and conductors are not in contact one another or with the metal housing of the connector.

Pin#1 and housing must never be connected to the power supply unit.

6.2 Power Unit

The **LEDko T/D DIM** can be also used with a power unit that allows an absolute dimming control for your fixture.

7. Turning the projector on

After having followed the preceding steps described, proceed with the power supply and turn on the projector connecting it to the mains power. Once you had connected the projector, use the potentiometer knob to regulate the luminous flux.

The software version installed on the internal microprocessors will be shown on the display, suddenly it will show the current DMX addressing. If the address blinks, it means that the DMX signal has not been received. Check the connection cable and the mixer functioning.

7.1 DMX address of the unit

Each projector can use 5 address channels for its complete operation and is controlled by a DMX 512 signal.

DMX addressing

When powered up initially, each projector will show "A001", which indicates that the fixture will start responding from the first DMX channel; **LEDko T/D DIM** also uses 5 DMX channels, which means that it will respond to the commands from channel 1 to channel 5 of your DMX 512 controller. Accordingly a second unit should be addressed as A006, a third one as A011 and so on. The operation must be carried out on every **LEDko T/D DIM** which has an address different from A001.

Altering the DMX address:

1. Press the + or – button until the display shows the required DMX address. The digits on the display will blink to indicate that the variation has not been registered.
2. Press the enter key to confirm your selection. The digits on the display panel will cease to blink and the projector will now respond to the new address.

Note: by holding the + or – button down the scrolling will be faster; thus allowing a faster selection

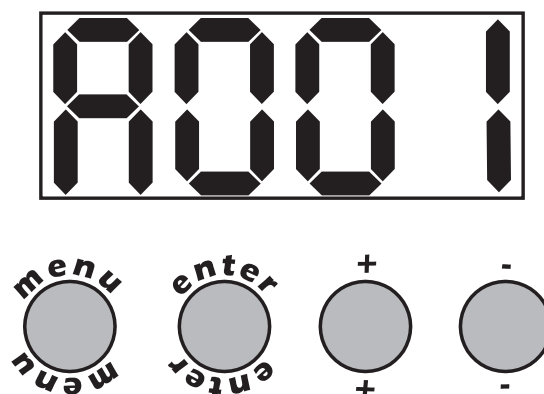

Warning!

If you alter the DMX address with no DMX signal connected, the digits on the display panel will continue to flash even after you have pressed ENTER button to confirm the address.

8. DMX chart

8.1 DMX modes

DMX channels ↓	
1	Master Dimmer
2	Spare Channel
3	Dimmer Fine
4	Strobe
5	Special Function

8.2 DMX Chart 5 channels

channel	function	type of control	effect	decimal		percentage	
				min	max	min	max
1	master dimmer	proportional	adjust luminous output intensity from 0 to 100%	0	255	0%	100%
2	spare channel	step	no effect	0	255	0%	100%
3	dimmer fine	proportional	fine dimmer control 16 bit	0	255	0%	100%
4	strobe	step	no effect	0	9	0%	4%
		proportional	variable speed strobing effect, from slow to fast	10	57	4%	22%
		step	stop strobe	58	59	23%	23%
		proportional	sequenced pulse effect, slow closing, fast opening (variable speed pulsing, from slow to fast)	60	108	24%	42%
		step	stop strobe	109	110	43%	43%
		proportional	sequenced pulse effect, fast closing, slow opening (variable speed pulsing, from slow to fast)	111	159	44%	62%
		step	stop strobe	160	161	63%	63%
		proportional	random strobe effect with variable speed from slow to fast	162	207	64%	81%
		step	stop strobe	208	209	82%	82%
		proportional	random strobe effect with variable speed from slow to fast	210	255	82%	100%
5	special functions	step	park, no effect	0	9	0%	4%
			640 Hz	10	84	4%	33%
			fan at low-noise speed	85	96	33%	38%
			fan at auto-silent speed	97	108	38%	42%
		proportional	fan speed control from minimum to maximum	109	120	43%	47%
		step	fan at maximum speed	121	133	47%	52%
			enables the automatic display blackout	134	185	53%	73%
			disables the automatic display blackout	186	199	73%	78%
			LED control frequency tuning 1000 Hz	200	223	78%	87%
			LED control frequency tuning 1500 Hz	224	255	88%	100%

9. Setup via RDM

9.1 Quick guide to menu

The LEDko DIM required RDM (Remote Device Management) to set up fixtures. Using an RDM compliant DMX controller, you can communicate with all the fixtures on a data link without needing to connect to each fixture individually. RDM lets you set the DMX addresses of all the fixtures on the link, carry out fixture configuration and retrieve fixture data including details of any error that has been logged. If two or more identical fixtures are set up with the same DMX address and in the same DMX mode, they will receive the same instructions and behave identically. Setting up identical fixtures with the same address is a good tool for troubleshooting unexpected behavior and an easy way to achieve synchronized action. Setting DMX addresses via RDM involves running a scan to identify the fixtures that are present on the data link and then allocating addresses either automatically or manually.

To use RDM:

1. Obtain an RDM-compatible controller such as the RDM UPGRADE INTERFACE B (cod. AC10011A001) application running on a Windows PC.
2. Use a USB cable to connect the PC to a USB/DMX interface box
3. Connect the interface box to the data link.
4. Power the fixture on and carry out an RDM discovery / scan in your RDM-compatible controller.
5. You can then configure or retrieve data from the fixtures on the data link.

9.2 RDM Chart

PARAMETER	DESCRIPTION
DMX ADDRESS	Set DMX Address: (1-512)
CURVE	Set Dimming Curve: Linear, Logarithmic, Exponential, Halogen, Standard
FREQUENCY	From 600 to 1.500 Hz
LOCK PIN	Set Lock Pin
LOCK STATE	Set Screen Lock
FACTORY DEFAULT	Factory Reset
PERSONALITY	Set Personality: 5
SENSOR	Visualize Sensor
LED HOURS	Visualize Led Life Hours
DEVICE HOURS	Visualize Device Life Hours

9.3 RDM Error Chart

ERROR	DESCRIPTION	SOLUTION
MEMORY	Memory Reading Error	Perform A "Factory Reset"
HW MEMORY	Memory Hardware Error	Contact Coemar
DMX ADDR	DMX Addressing Error	The Personality Dimension Exceeds 512 Channels
NTC ERROR	Temperature Sensor Disconnected	Check Wiring NTC Led
SHORT NTC	Short-Circuited Temperature Sensor	Check Wiring NTC Led
OVER TEMP	Electronic Board Overtemperature	Ambient temperature too high, place the projector in an environment with temperature below 40°C

10. Display panel functions

10.1 Quick guide to menu

To access the functions menus just press the MENU button. Then press + or – buttons to scroll the pages and press the ENTER button to access to any other function.

By suitably using all the functions of **LEDko T/D DIM**, which can be activated through its display panel, it is possible to change some of the parameters and to add some functions. Changing the preset settings made by **Coemar** can vary the functions of the projector so that it will respond differently to the controller; therefore carefully read about the functions described here before carrying out any possible selection.

10.2 Rapid count

Through the display panel of **LEDko T/D DIM** it is possible to quickly change the various numbers displayed for the different functions in the following 3 manners:

1. Pressing the + or – buttons will cause the count to be quicker.
2. Pressing first + and then – and then holding them down simultaneously will cause the numbers to jump to the highest value.
3. Pressing first – and then + and then holding them down simultaneously will cause the number to jump to the lowest value.

10.3 Main functions menu

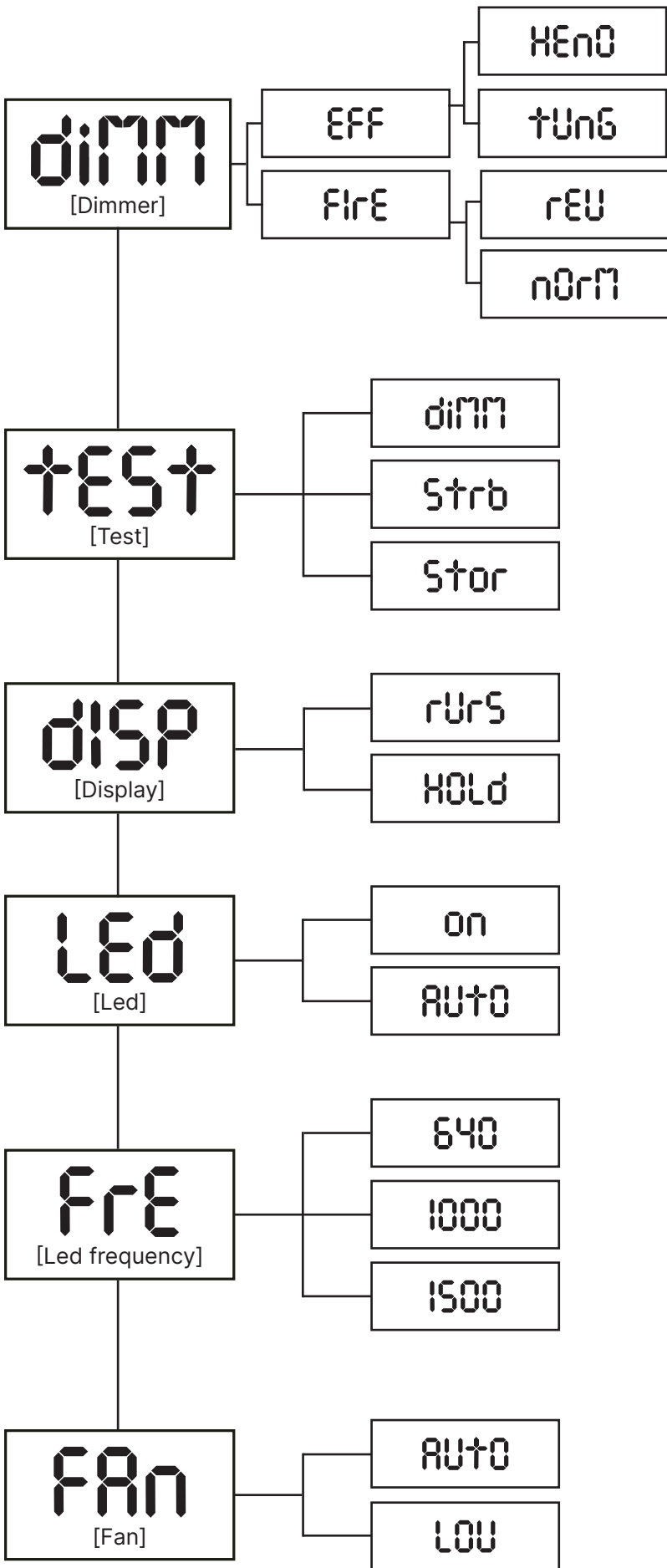

Dimmer:

Choose the type of dimmer curve:

- **Xeno:** quick curve;
- **Tungsten:** mimics the slow dimming curve of tungsten lamps;
- **Reverse:** inversion phase of the Dimmer Power Unit;
- **Normal:** forward phase of the Dimmer Power Unit.

Test:

Allows to manually set the DMX channels controlled by a DMX console:

- **Dimmer:** sets the luminous intensity;
- **Strobe:** manually sets the strobe DMX channel;
- **Store:** stores the modifications that will be set at the next times the fixture will be turned on.

Display:

It allows to turn 180° the reading of the display. HOLD locks the keys. Press any key for 5" to unlock.

Led:

AUTO allows to turn off the display after 6 seconds.

LED Frequency:

It allows to set the flickering frequency from 640 to 1.500 Hz besides the default value. (NOTE: DMX signals goes ahead this setting).

Fan Speed:

- **Auto:** under this setting the fan speed varies based on the overall temperature of the fixture to guarantee the maximum output possible;
- **Low noise:** this setting will keep the speed of the fan at the minimum level while the light output will decrease in case of overheat.

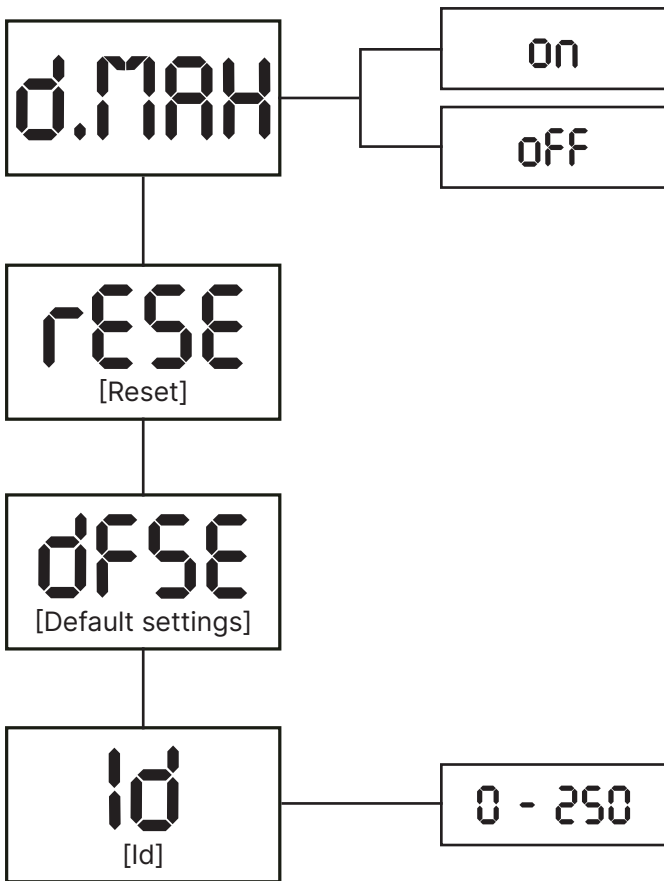

d.MAX:

Disables the adjusting of the leds setting them at maximum output.

Reset:

It permits the reset of the unit. Keeping pressed ENTER and MENU at the turning on of the unit It allows to access ALIG features.

Default settings:

Restores all the settings to default value except for led settings, hour and DMX address.

Id:

It allows to set the ID number of the unit by + and - keys; "enter" key to confirm.

10.4 Measures menu (MEAS)

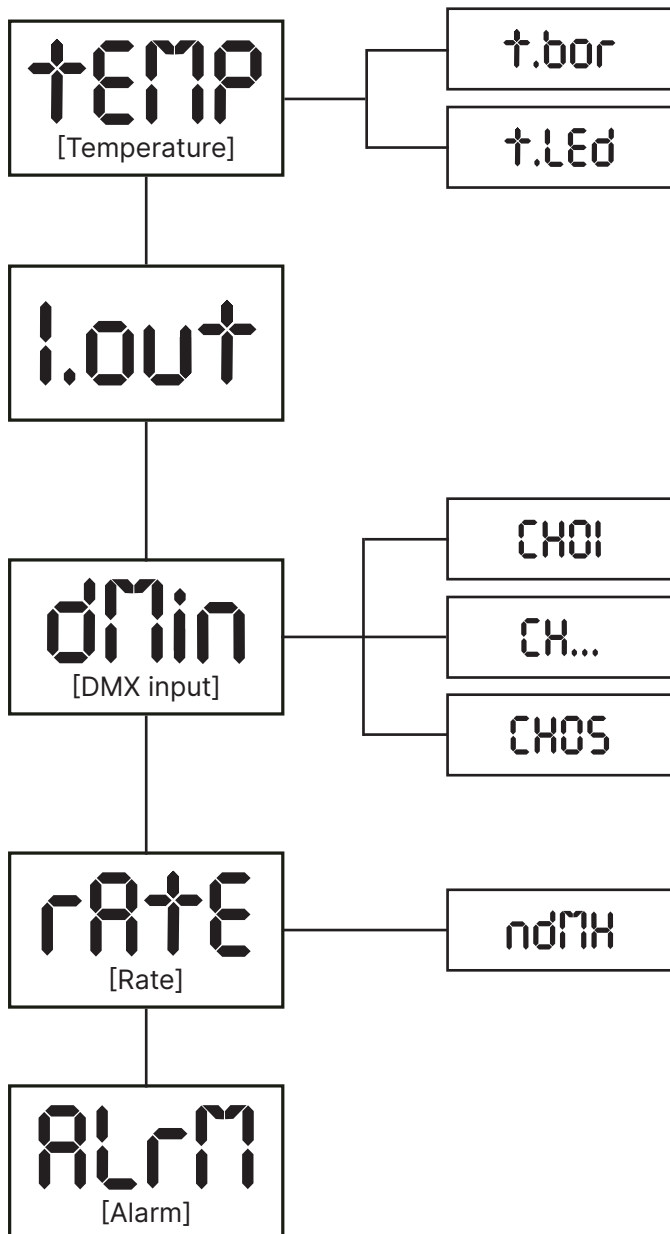

Temperature:

Shows the current temperature values:

- **LED:** shows the LED module temperature;
- **Board:** shows the electronic board temperature.

I.out:

shows the current output of the LED.

DMX Input:

Shows the value of the DMX channels received by the fixture on every channel that the fixture occupies on the line.

Rate:

Shows the refresh rate of the DMX signal sent by the console.

Alarm:

This menu shows the alarm status-es if there is any.

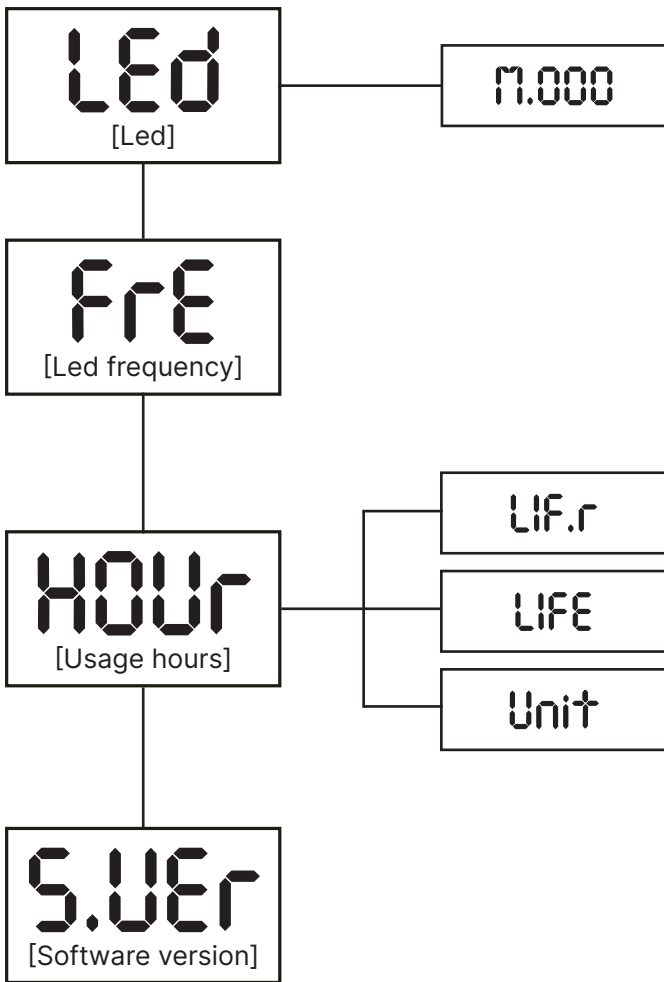

LED:

Shows the percentage value of the LED status.

LED frequency:

Shows the operating frequency of the LED.

Usage hours:

Shows the hour counter of the fixture:

- **Unit:** shows the overall hours of life of the fixture;
- **LED life:** shows the overall LED module life;
- **LED life reset:** shows the overall LED module life currently installed;

Note: this items can be reset in case of LED module replacement.

Software version:

Shows the software version currently installed in the fixture.

10.5 Special functions of the fixture

Storing the DMX signal

To use the fixture without an active DMX console it is possible to store the DMX settings in two ways:

- Through the **TEST** menu;
- Disconnecting the DMX signal when the fixture is on. When the signal is unconnected the fixtures stores the signal;

Automatic fan standby

To decrease the noise and the power consumption the cooling fan turns off after 10 minutes of fixture inactivity.

10.6 Error messages

If a malfunction occurs, **LEDko T/D DIM** has a self-diagnostic system that will show the error message on the display. The following table will explain in detail the most common errors. If, despite of suggested intervention, the problem persists, call the **Coemar** Service Center.

Error code	Description
noal [No Alarm]	No Alarm The projector self-diagnostic routine didn't find any issue.
DTER [Data Error]	Data error Initial data loading has failed the projector loaded the default data settings: restart the fixture again, and if the error persists contact the Coemar assistance center.
ADER [Address Error]	Address error The projector does not receive all channels of DMX needs to function properly. Check the DMX address indicated on the display and the number of channels generated by the mixer control. We recall in this connection that some controllers do not generate all the 512 channels.
LED [LED Error]	LED error Auto diagnostic routine found that the LED module may damaged, contact Coemar assistance for the module replacement. IMPORTANT: To ensure the sensor is giving correct readings, set the LED to the maximum light output level.

11. Accessories and spare parts

LEDko T/D DIM is a very versatile fixture, optional accessories for its customization are available under request:

Accessory name	Code
Front barrel for lens tube with burnished blades	BC10011A200
Profile 5°, lens tube	BC10011A041
Profile 10°, lens tube	BC10011A042
Profile 14°, lens tube	BC10011A023
Profile 19°, lens tube	BC10011A012
Profile 26°, lens tube	BC10011A013
Profile 36°, lens tube	BC10011A015
Profile 50°, lens tube	BC10011A016
Profile 70°, lens tube	BC10011A024
Profile 90°, lens tube	BC10011A025
Profile Zoom 15°- 35°	BC10011A017
Profile Zoom 25°- 50°	BC10011A019
Profile Zoom 28°- 40°	BC10011A003
Soft Profile Fresnel Zoom 14°- 40°	BC10011A002
Soft Profile PC Zoom 11°- 38°	BC10011A001
4 leaf barndoor	ACO4202
Gobo frame holder	BC10011A006
Iris	BC10011A010
Donut (190.5 mm)	BC10011A028
Half Top Hat (190.5 mm)	BC10011A027
Top Hat (190.5 mm)	BC10011A029
Color Frame Holder (190 mm)	BC10011A040
Donut (185 mm)	BC10011A036
Half Top Hat (185 mm)	BC10011A035
Top Hat (185 mm)	BC10011A037
Color Frame Holder (185 mm)	ACO4204

Donut (159 mm)	BC10011A032
Half Top Hat (159 mm)	BC10011A031
Top Hat (159 mm)	BC10011A033
Colour Frame Holder (159 mm)	BC10011A021
(Gobo Slot) Glass template holder (93.6 mm)	BC10011A030
Hook clamp, 48-51 mm, max. load 20 Kg.	BC10011A047
Light clamp silver, 48-51 mm, max. load 75 Kg.	BC10011A045
Light clamp black, 48-51 mm, max. load 75 Kg.	BC10011A046
Clamp silver, flat 13-30 mm/ø 15-50 mm, max. load 20 Kg.	BC10011A043
Clamp black, flat 13-30 mm/ø 15-50 mm, max. load 20 Kg.	BC10011A044

All the components of **LEDko T/D DIM** are available as spare parts from your **Coemar** dealer or Service. Accurate description of the fixture, model number and type will assist us in providing for your requirements in an efficient and effective manner.

12. Maintenance

12.1 Firmware update

The firmware of **LEDko T/D DIM** can be updated through the RDM protocol (ANSI E1.20). Contact Coemar assistance to receive the software and the device updater.

12.2 Periodic cleaning

Lenses

Even a thin layer of dust can reduce the luminous output and alter the consistency of the beam. Regularly clean all filters and lenses using a soft cotton cloth, dampened with a special lens cleaning solution.

Cleaning of the unit

Use a soft brush or a common vacuum cleaner or a source of compressed air for removing dust. For the cleaning of the housing use a soft cloth and a non-aggressive cleaner. Check that the internal fans and heat exchanger must be perfectly clean.

12.3 Periodic controls

Mechanical components

Check the correct working of the mechanical parts and, if needed, replace them. Make sure the projector is not mechanically damaged. If necessary, replace the worn parts.

Electrical components

Check all electrical connections, in particular for correct grounding and correct attachment of all extractable connectors. Press the connectors if necessary and reposition as before.

12.4 Fuses

LEDko T/D DIM has an automatic fuse that in most cases does not need to be replaced.

13. F.A.Q. and answers

The following list shows common issues that may be simply solved. If issues persist, the unit must be repaired by a qualified personnel or just contact your **Coemar** service near you.

Question	Possible solution
LEDko T/D DIM does not emit light	Projector not powered on: <ul style="list-style-type: none">• Make sure the power cable is plugged in or test the input voltage; Wrong DMX address: <ul style="list-style-type: none">• Check the DMX Address setting and the output signal of the controller;
LEDko T/D DIM is not responding to DMX signal	DMX signal may not reach LEDko T/D DIM: <ul style="list-style-type: none">• Inspect the cable connection, correct poor connections or inefficient repair or replace damaged cables;• Check DMX address of the unit;

Help from Coemar Technical Services

If you are having difficulties and your problem is not addressed by this document, contact Coemar Technical Services directly at one of this email address:

info@coemar.com / service@coemar.com

Or call the number **+39 0376 1514412**

When calling for help, take these steps first:

- Prepare a detailed description of the problem
- Go near the equipment for troubleshooting

User notes

A series of horizontal rows of dotted lines, providing a template for user notes.



Information on disposal of the equipment

The equipment at the end of its useful life must be disposed of at an appropriate recycling center for waste electrical and electronic equipment. The treatment and disposal of environmentally friendly, helps prevent potential negative environmental and health and promote the reuse and / or recycling of materials making up the equipment. Illegal disposal by the user includes the application of administrative sanctions provided by law.



Coemar Lighting s.r.l.

Via Carpenedolo 90
46043 Castiglione delle Stiviere, Mantova, Italy
phone. +39 0376/1514412 - fax +39 0376/1514380
info@coemar.com

Coemar reserves the right to change specifications without prior notice