

LEDKO™ EXT + FullSpectrum RGBLA

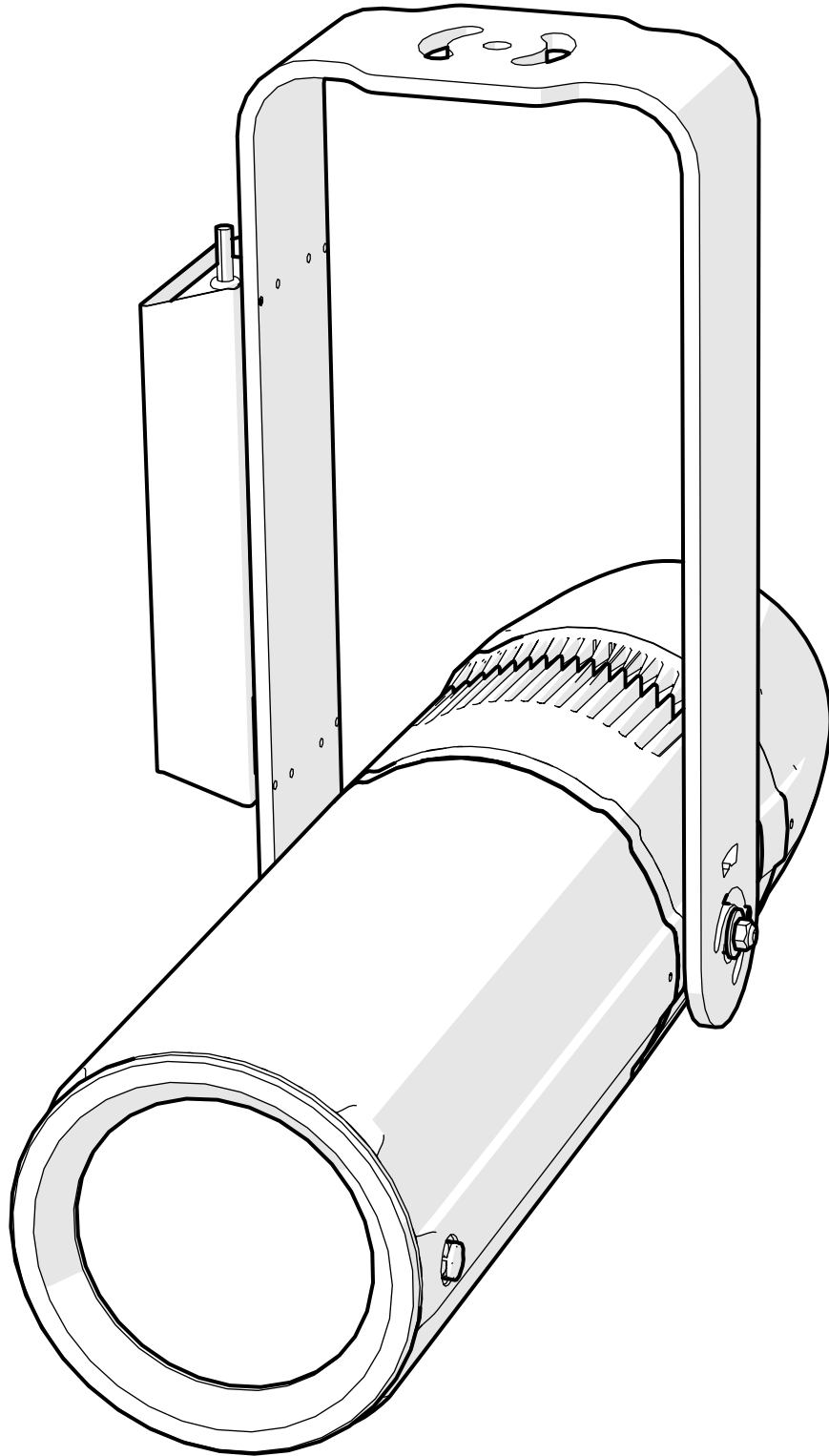

USER MANUAL
vrs. 1.6 - 26.02.2024

© 2023 Coemar Lighting Srl. All rights reserved.

Information subject to change without notice. Coemar and all affiliated companies disclaim liability for any injury, damage, direct or indirect loss, consequential or economic loss or any other loss occasioned by the use of, inability to use or reliance on the information contained in this document. The Coemar logo, the Coemar name and all other trade-marks in this document pertaining to services or products by Coemar or its affiliates and subsidiaries are trademarks or licensed by Coemar or its affiliates or subsidiaries.

No part of this document may be used for distribution, reproduction, transmission, transcription, storage in a data retrieval system, or translated into any language in any form by any means without the prior written permission of Coemar ®. If you are downloading files from our web pages for your personal use, make sure to check for updated versions. Coemar ® cannot take any liability whatsoever for downloaded files, as technical data are subject to change without notice.

Congratulations on having purchased a Coemar product. You have assured yourself of a fixture of the highest quality, both in componentry and in the technology used. We renew our invitation to you to complete the service information on the previous page, to expedite any request for service information or spares (in case of problems encountered either during, or subsequent to, installation). This information will assist in providing prompt and accurate advice from your Coemar service centre. Following the instructions and procedures outlined in this manual will ensure the maximum efficiency of this product for years to come.

Index

1. Packaging and transportation	Pag. 5
1.1 Packaging	Pag. 5
1.2 Transportation	Pag. 5
2. General information	Pag. 5
2.1 Safety informations	Pag. 5
2.2 Warranty conditions	Pag. 6
2.3 EC Norms	Pag. 6
3. Product specifications	Pag. 7
3.1 Technical characteristics.....	Pag. 7
3.2 Dimensions.....	Pag. 8
3.3 Unit's main components.....	Pag. 9
3.4 Back panel description	Pag. 10
4. Installation	Pag. 11
4.1 Mechanical installation	Pag. 11
4.2 Safety chain	Pag. 11
4.3 Adjusting unit's tilt	Pag. 12
4.4 Optical group and framing system	Pag. 12
4.5 How to insert a metal gobo	Pag. 17
4.6 How to insert a glass gobo.....	Pag. 18
5. Powering up	Pag. 19
5.1 Operating voltage and frequency	Pag. 19
5.2 Connection to mains power.....	Pag. 19
5.3 How to connect the Power Junction Connector	Pag. 20
6. Control signal connections	Pag. 21
6.1 Control signal connection by IP67 Junction Connectors	Pag. 21
7. Turning the projector on	Pag. 23
7.1 DMX address of the unit	Pag. 23
8. DMX chart	Pag. 24
8.1 DMX modes.....	Pag. 24
8.2 DMX Chart 16, 7, 1 channels	Pag. 25
8.3 DMX Chart Studio Mode.....	Pag. 28
8.4 DMX Chart RGB Mode	Pag. 29
8.5 DMX Chart fine RGB Mode	Pag. 31
8.6 DMX Chart SUNRISE Mode	Pag. 33

9. Setup via RDM	Pag. 34
9.1 Quick guide to menu	Pag. 34
9.2 RDM Chart.....	Pag. 34
9.3 RDM Error Chart	Pag. 35
10. Display panel functions	Pag. 36
10.1 Quick guide to menu	Pag. 36
10.2 Rapid count	Pag. 36
10.3 Main functions menu	Pag. 37
10.4 Settings	Pag. 40
10.5 Display	Pag. 43
10.6 Effects.....	Pag. 45
10.7 Measures	Pag. 47
11. Wi-Fi Menu (OPTIONAL)	Pag. 49
12. Special Function and Error Messages	Pag. 50
12.1 Special functions of the fixture	Pag. 50
12.2 Error messages	Pag. 50
13. Accessories and spare parts	Pag. 51
14. Maintenance	Pag. 52
14.1 Firmware update.....	Pag. 52
14.2 Periodic cleaning	Pag. 52
14.3 Periodic controls.....	Pag. 52
15. F.A.Q. and answers	Pag. 53

1. Packaging and transportation

1.1 Packaging

Open the packaging and make sure that no part of the equipment has suffered any damage during the transportation. In case of damage to the fixture, contact your carrier and your supplier immediately by telephone, fax or e-mail, and inform them you will formally notify them in writing through registered letter.

Packing list

Ensure the packaging contains:

1 LEDko EXT FS RGBLA +

1 Power Junction connector (IP67)

2 DMX Junction connector (IP67)

1 DMX end of line closure cap

1 Instruction manual

1.2 Transportation

The **LEDko EXT FS RGBLA +** should be transported in either its original packaging or in an appropriate flight case.

2. General information

2.1 Safety informations

Fire prevention:



1. Never locate the fixture on any flammable surface.
2. Minimum distance from flammable materials: 0,5 m.
3. Minimum distance from the closet illuminable surface: 0,5 m.
4. Connect the projector to mains power protected by a thermal magnetic circuit breaker.

Prevention from electric shock:



1. Presence of high voltage inside of the fixture. Insulate the projector from mains supply before opening or performing any function which involves touching the inside of the fixture, including LED replacement.
2. For the connection to the mains, adhere strictly to the guidelines outlined in this manual.

3. The level of technology of **LEDko EXT FS RGBLA +** requires the use of specialised personnel for all service applications; refer all work to your authorised **Coemar** service centre.
4. A good earth connection is essential for the proper functioning of the projector. Never connect the fixture if there is no earth connection.
5. Mains cables must not come into contact with other cables.
6. Do not operate the projector with wet hands or in an area where water is present.
7. The fixture must never be located in an exposed position, or in areas of extreme humidity.

Safety:



1. The projector must always be installed with bolts, clamps, or other fixing devices which are suitably rated to support the weight of the projector.
2. Always use a secondary safety fixing device with chain or steel wire of a suitable rating to sustain the weight of the unit in case of failure of the principal fixing point.
3. The external surfaces of the unit, at various points, may reach 60°C. Never handle the unit until at least 10 minutes have elapsed since the LED was turned off.
4. Never install the fixture in an enclosed area lacking sufficient air flow; the ambient temperature must not exceed 40°C.
5. The projector contains electronic and electrical components which must under no circumstances be in contact with water, oil or any other liquid. Failure to do so will compromise the proper functioning of the projector.

2.2 Warranty conditions

1. The fixture is under warranty for 24 months from the purchase date against factory defections.
2. Damage ought to unskillfulness, inappropriate use, or lack of suggested maintenance are excluded from the warranty.
3. Warranty expires when the projector is opened by unauthorized personnel.
4. Warranty doesn't include the replacement of the fixture.
5. Serial number and model of the fixture are necessary to retrieve informations and assistance from the dealer.

2.3 EC Norms

1. The fixture satisfies the essential requirements of the directive 2004/108/EC, 2006/95/EC, 2011/65/EC, 2002/96/EC & 2003/108/EC.
2. The fixture is in accordance with the standard EN 50419 (RoHS) and satisfies the requirements of the directive 2002/96/EC (WEEE).

3. Product specifications

3.1 Technical characteristics

Power supply	80-264 V, auto-sensing, 50/60 Hz
Maximum current	1.16 A at 230 W, 2.34 A at 115 W
Power factor	Cosφ = 0.93
Max power consumption	250 W
Color mixing	RGBLA LEDs module (Red, Green, Blue, Lime, Amber color mixing with hue and saturation control)
Color Rendering Index (CRI)	CRI > 85
Weight	(14°-35°) 14 Kg / 30.8 lbs - (10°-25°) 15 Kg / 33.1 lbs
	(80°) 12.1 Kg / 26.6 lbs - (30°-60°) 12.6 Kg / 27.7 lbs
Storage temperature	from - 40° C / -40° F to + 85° C / +185° F
Operating temperature	from - 40° C / -40° F to + 40° C / +104° F
IP rating	65

3.2 Dimensions

LEDko EXT 80° Optic

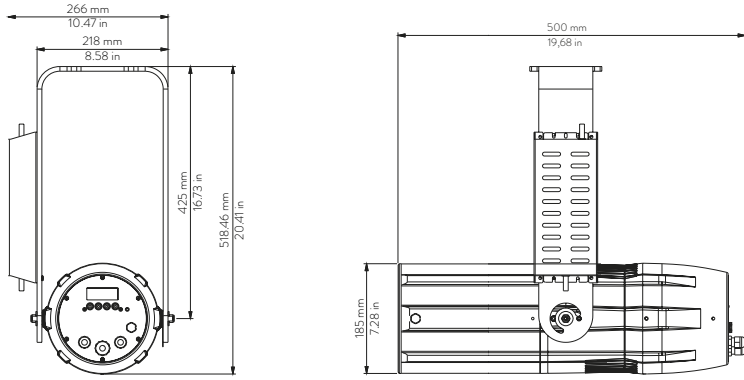

Length	Width	Height	Weight
500 mm 19.68 in	252.6 mm 9.94 in	185 mm 7.28 in	12.1 Kg 26.6lbs

With
bracket:
518.46 mm
20.41 in

LEDko EXT 30°-60° Zoom

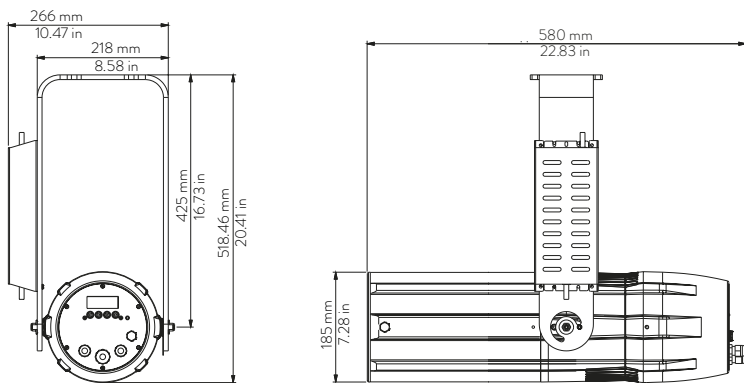

Length	Width	Height	Weight
580 mm 22.83 in	252.6 mm 9.94 in	185 mm 7.28 in	12.6 Kg 27.7 lbs

With
bracket:
518.46 mm
20.41 in

LEDko EXT 14°-35° Zoom

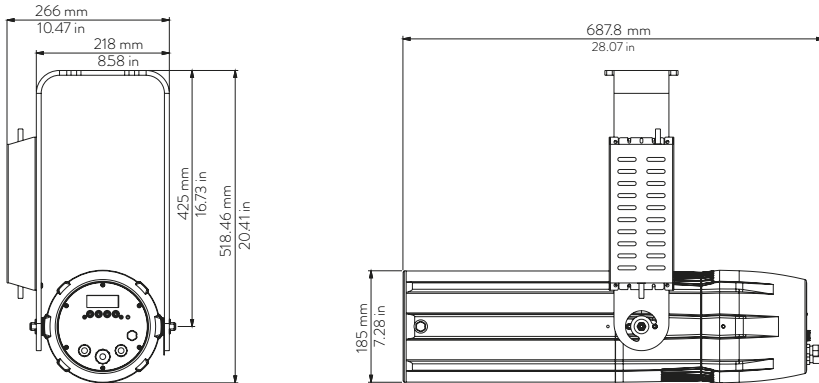

Length	Width	Height	Weight
687.8 mm 27.07 in	252.6 mm 9.94 in	185 mm 7.28 in	14 Kg 30.8 lbs

With
bracket:
518.46 mm
20.41 in

LEDko EXT 10°-25° Zoom

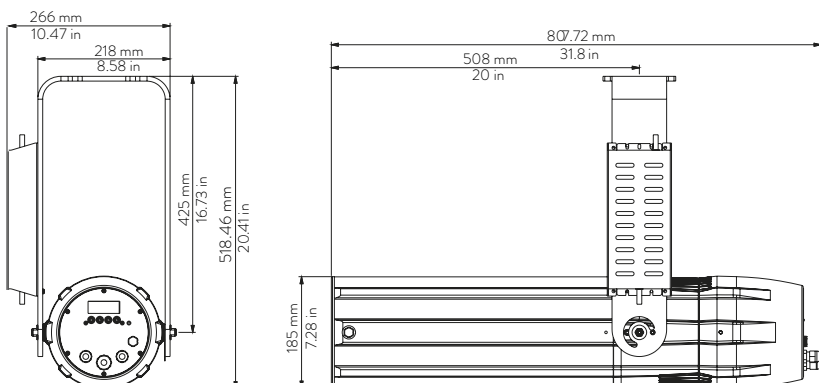

Length	Width	Height	Weight
807.2 mm 31.8 in	252.6 mm 9.94 in	185 mm 7.28 in	15 Kg 33.1 lbs

With
bracket:
518.46 mm
20.41 in

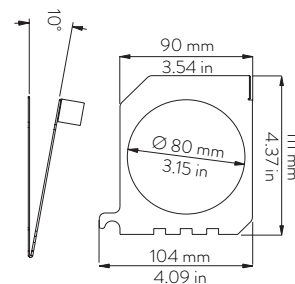

Gobo holder

3.3 Unit's main components

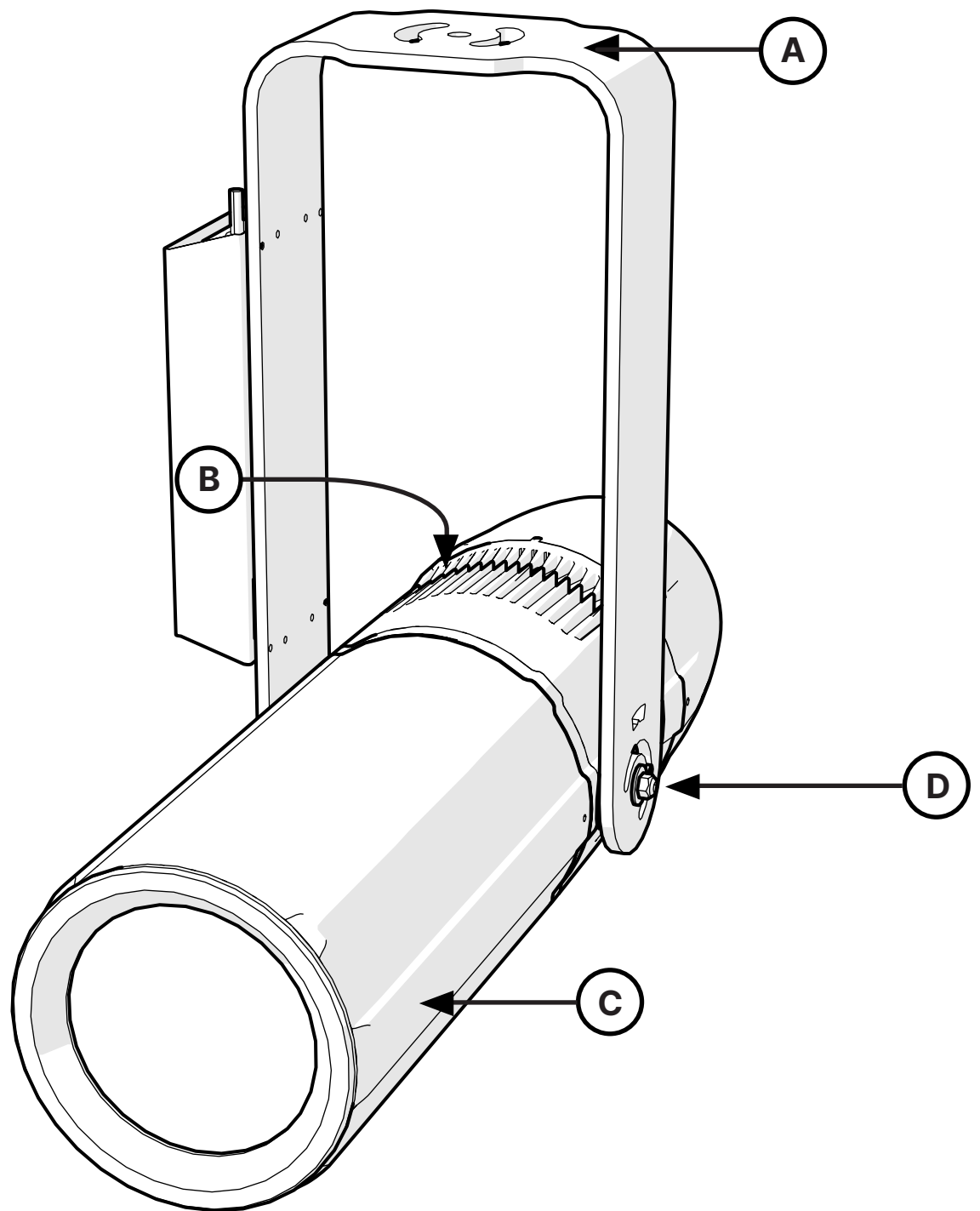

Components description

A	Yoke with mounting holes
B	Cooling unit
C	Optical holder tube
D	Locking screw for yoke

3.4 Back panel description

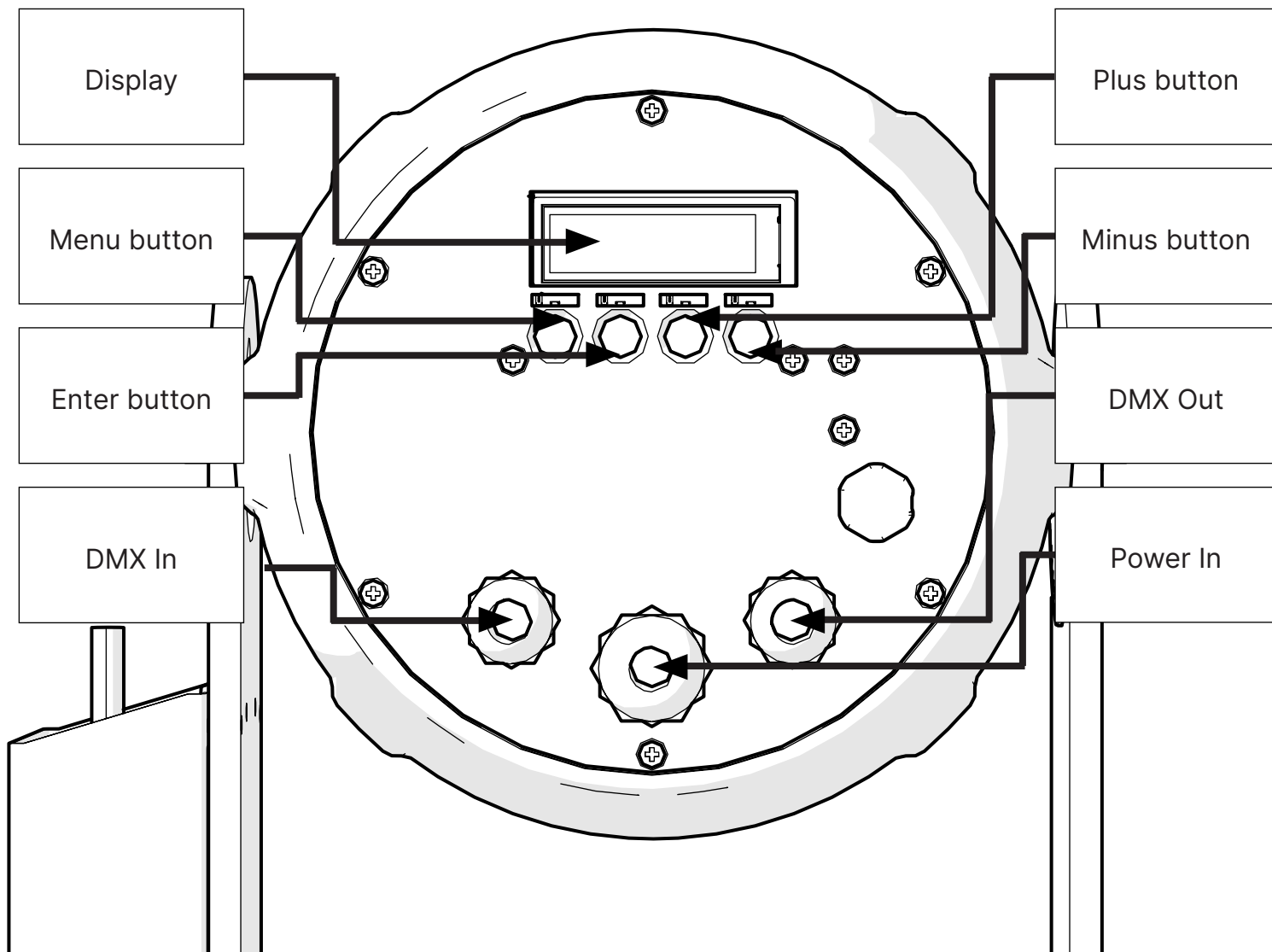

4. Installation

4.1 Mechanical installation

LEDko EXT FS RGBLA + may be hung from an appropriate structure in any position. If hanging the fixture from a lighting truss or similar, we recommend the use of an appropriate clamp "A", as shown in the following diagram.

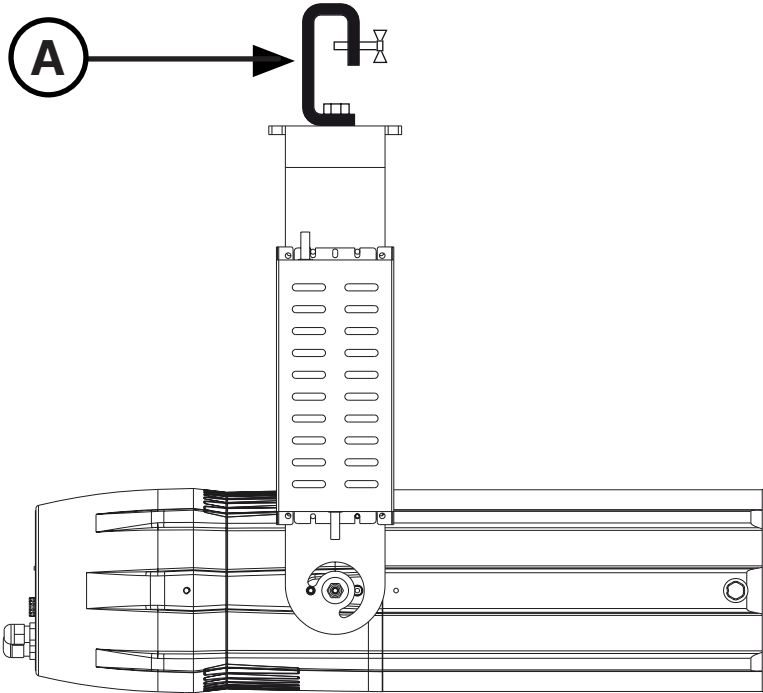

Warning!!
Always ensure that your support structure and fixing (bolts, clamps, etc...) are rated A to support the weight of the fixture.

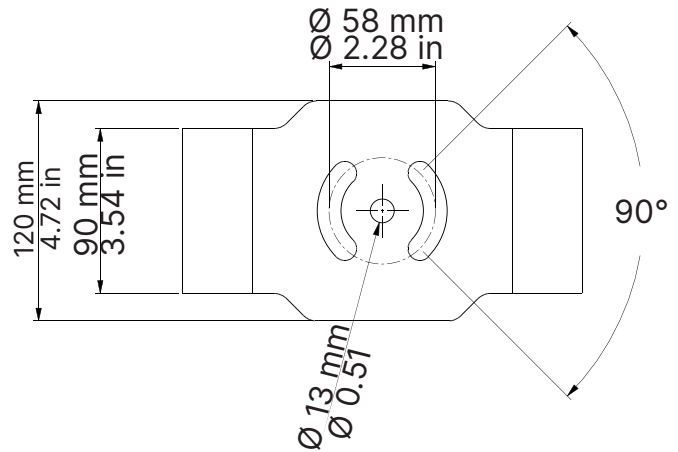

4.2 Safety chain

When hanging it is recommended to use a safety chain, as required by current legislation. The safety chain must pass through the handles of the unit and then attached to the structure. If using steel cables and chains not 's production, make sure they are suitable to support the weight of the unit according to normative UL/ETL (required: the weight of 6 complete devices for at least one hour).

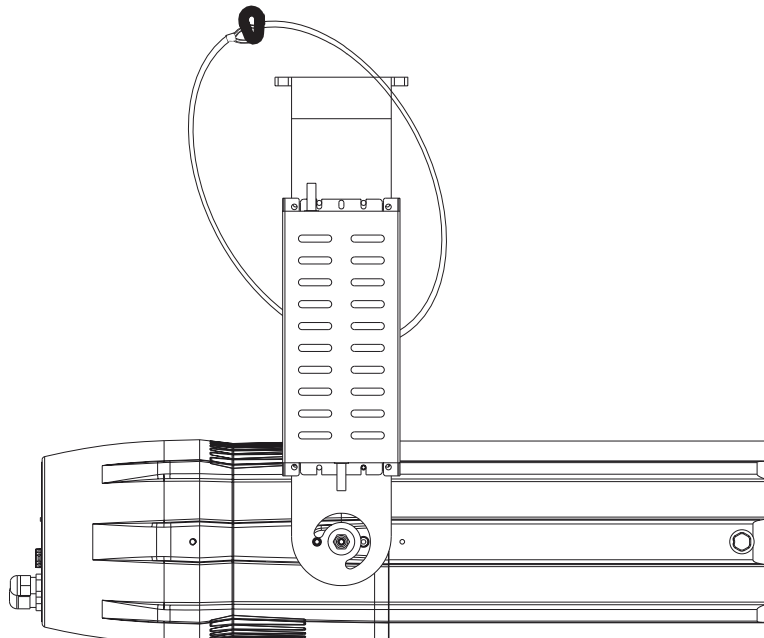

4.3 Adjusting unit's tilt

In order to adjust the tilt of the unit simply loose the side screw "B" on the yoke, adjust the tilt and lock the yoke by tightening the screw again.

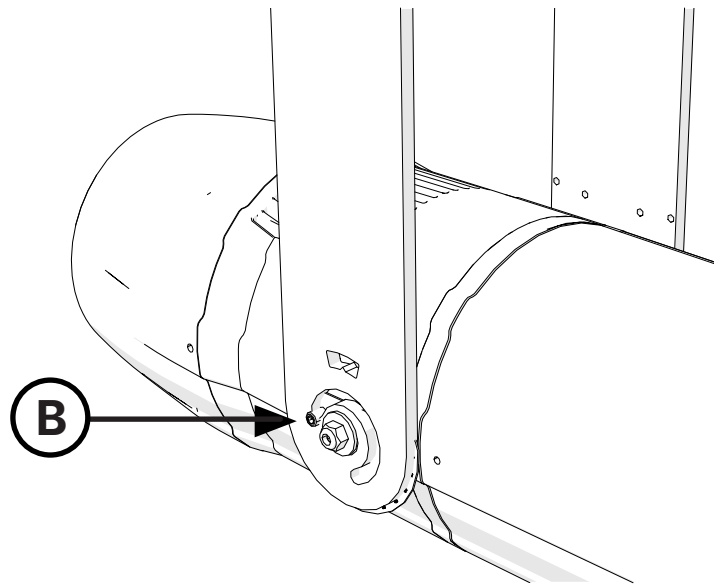

4.4 Optical group and framing system

Follow these steps in order to configure the optical group properly:

1. Remove the two screws "C" placed on both sides of the optical holder tube;
2. Gently remove the optical holder tube "D" pulling it away from the body;

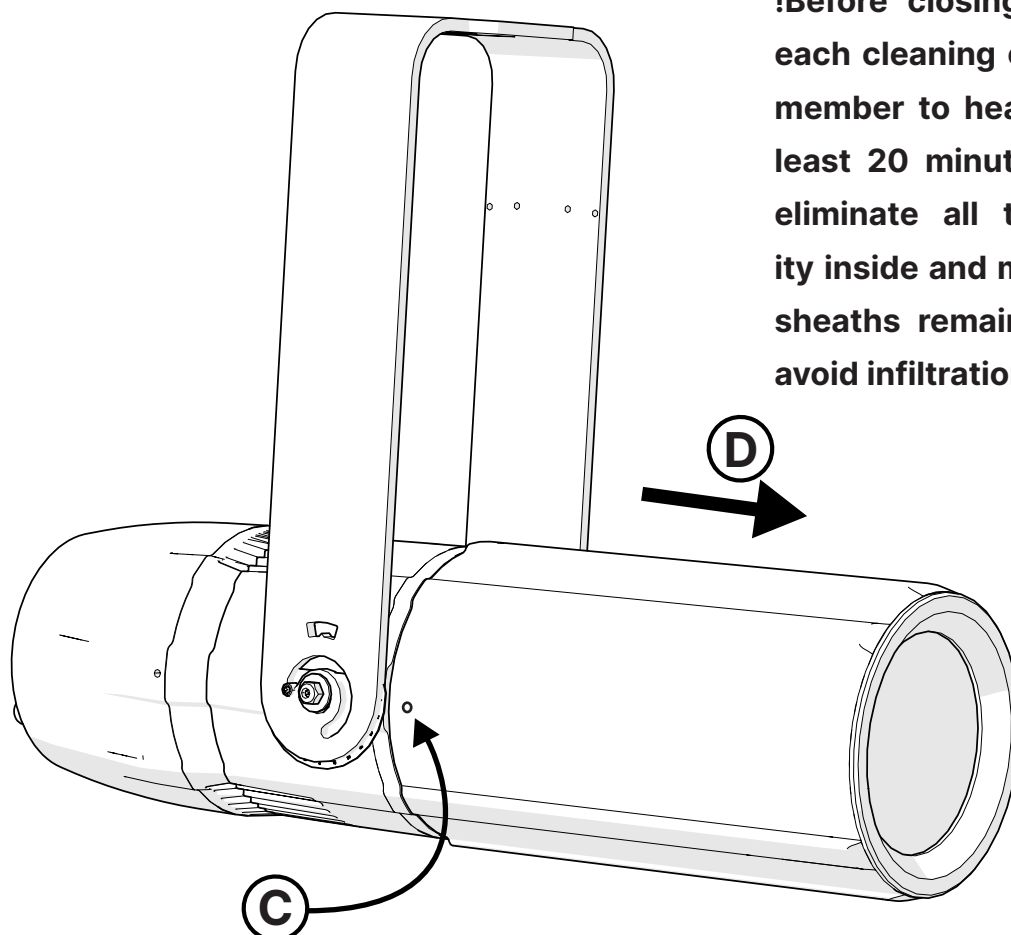

!Before closing the cover after each cleaning or adjustment, remember to heat the LEDs for at least 20 minutes, to be sure to eliminate all traces of humidity inside and make sure that the sheaths remain in their seat to avoid infiltrations.

3. Loose the thumbscrews “E” of the two lenses to set them at desired position. Turn on the fixture and check if the desired focus and zoom lever are correct, then tighten the thumbscrews;

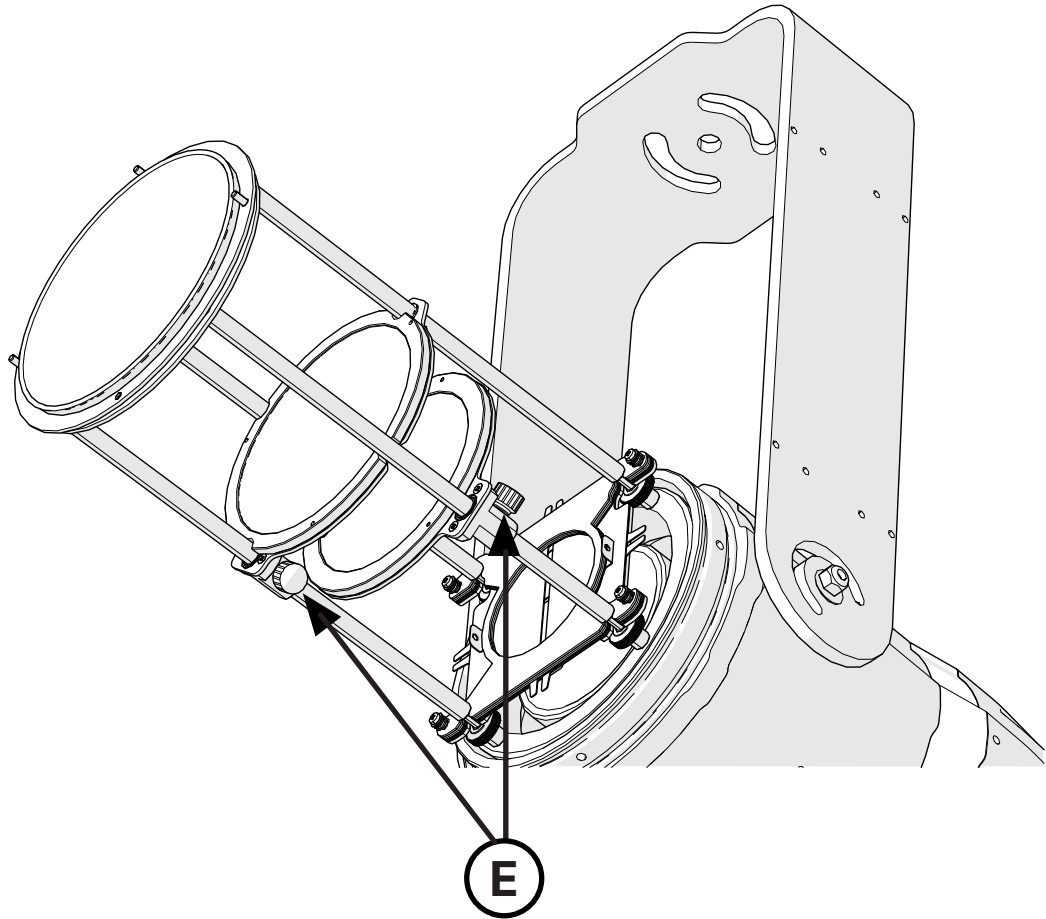

4. In order to change the optical group, once the optical holder tube is removed, loosen the two screws on the top and bottom sides “F”.

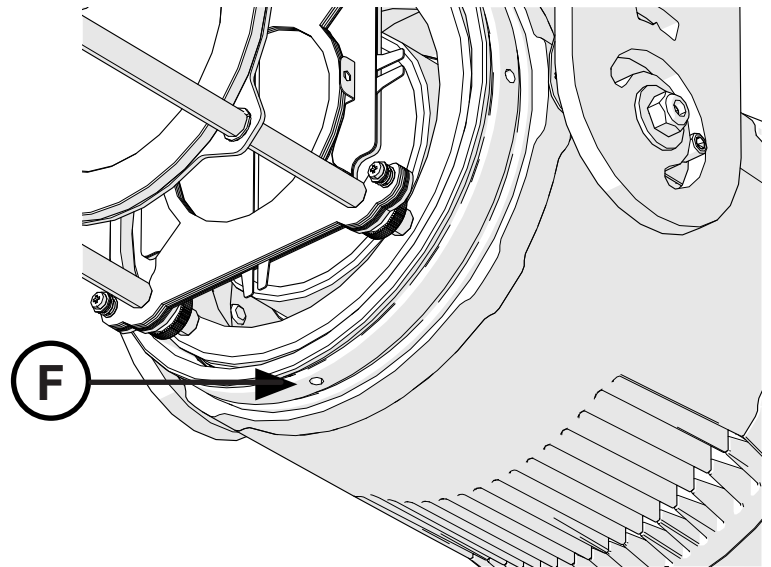
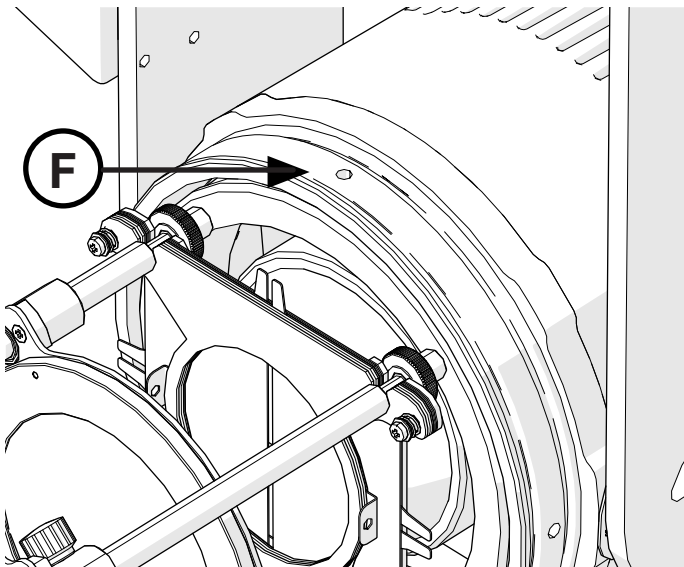

5. Turn the optical group "G" counterclockwise and pull it away.

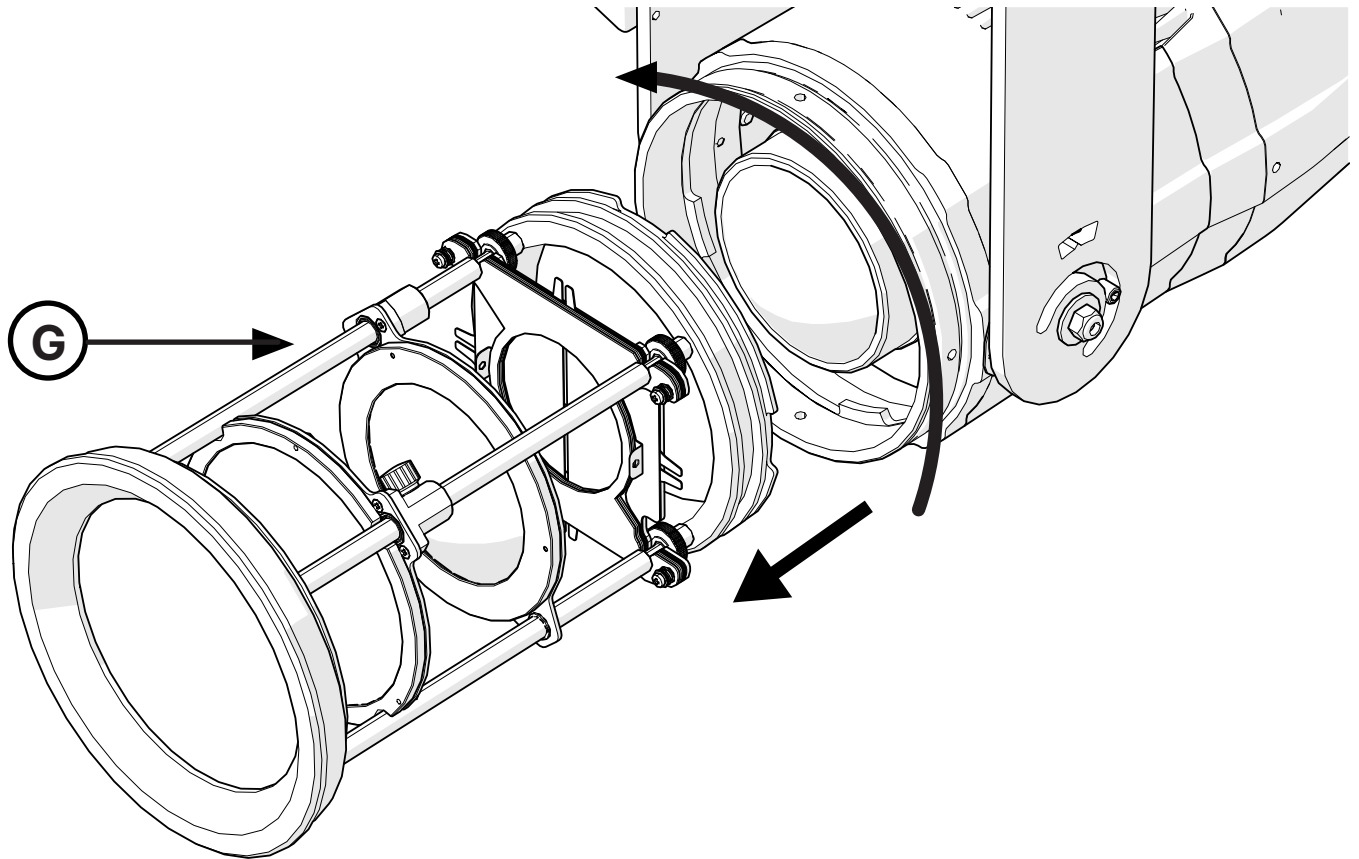

6. Choose another optical group, place it and turn it clockwise. Tighten the screws on the top and bottom sides

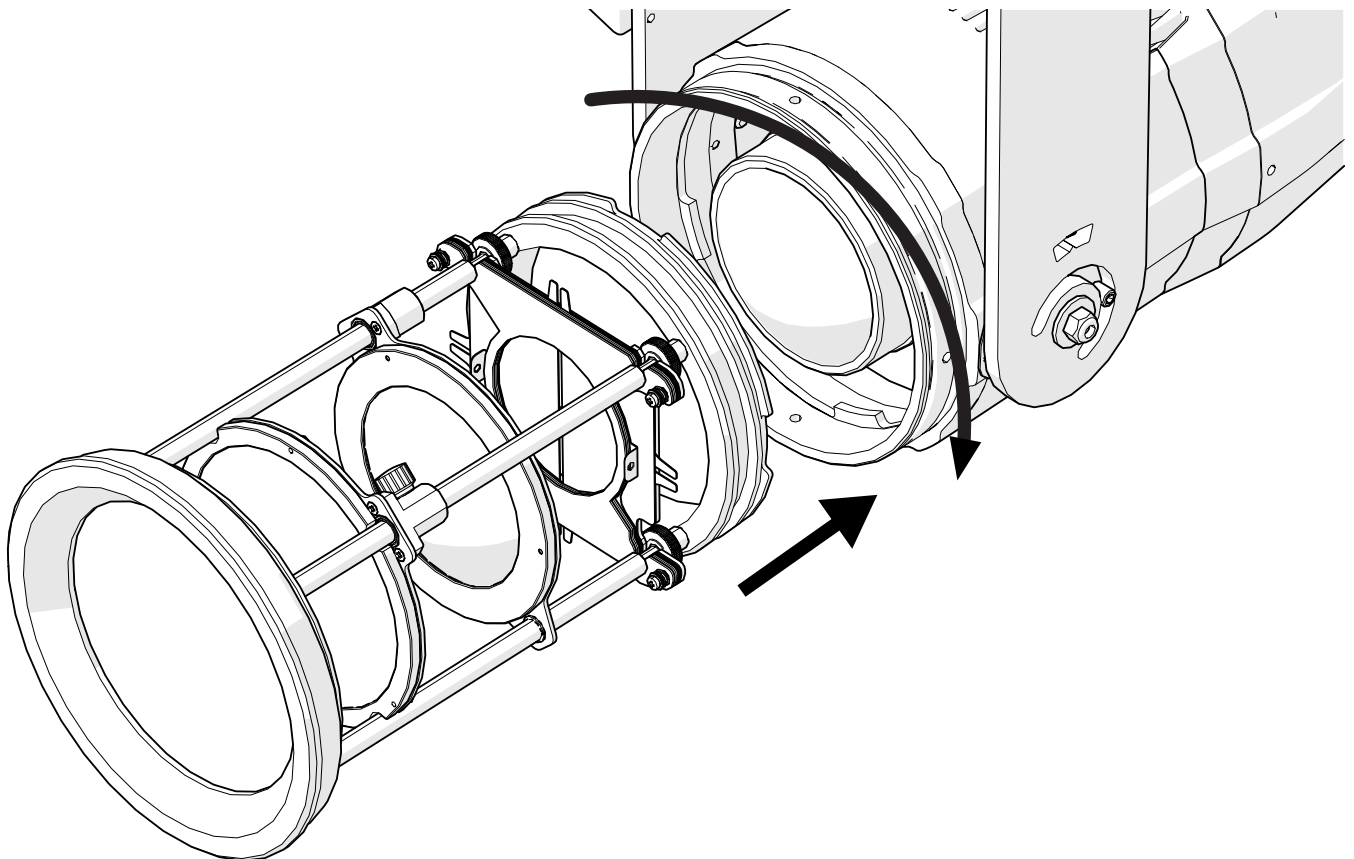

7. It is possible to regulate the shutter blades "H" to achieve the desired shape, use the four thumb screws "I" that you can see behind the shutter blades to free or block them;

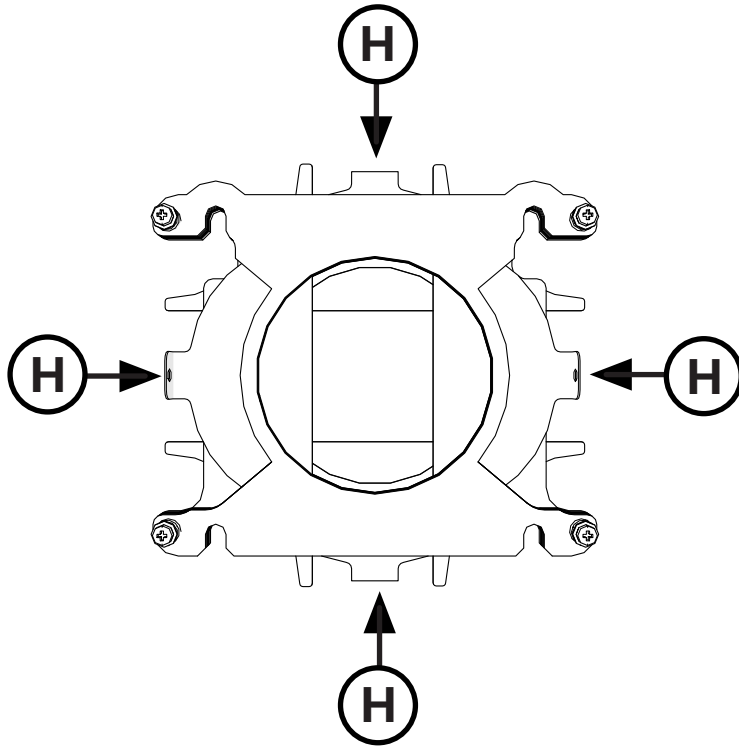

Four blade framing system, each shutter blade is adjustable for radial position and angle.

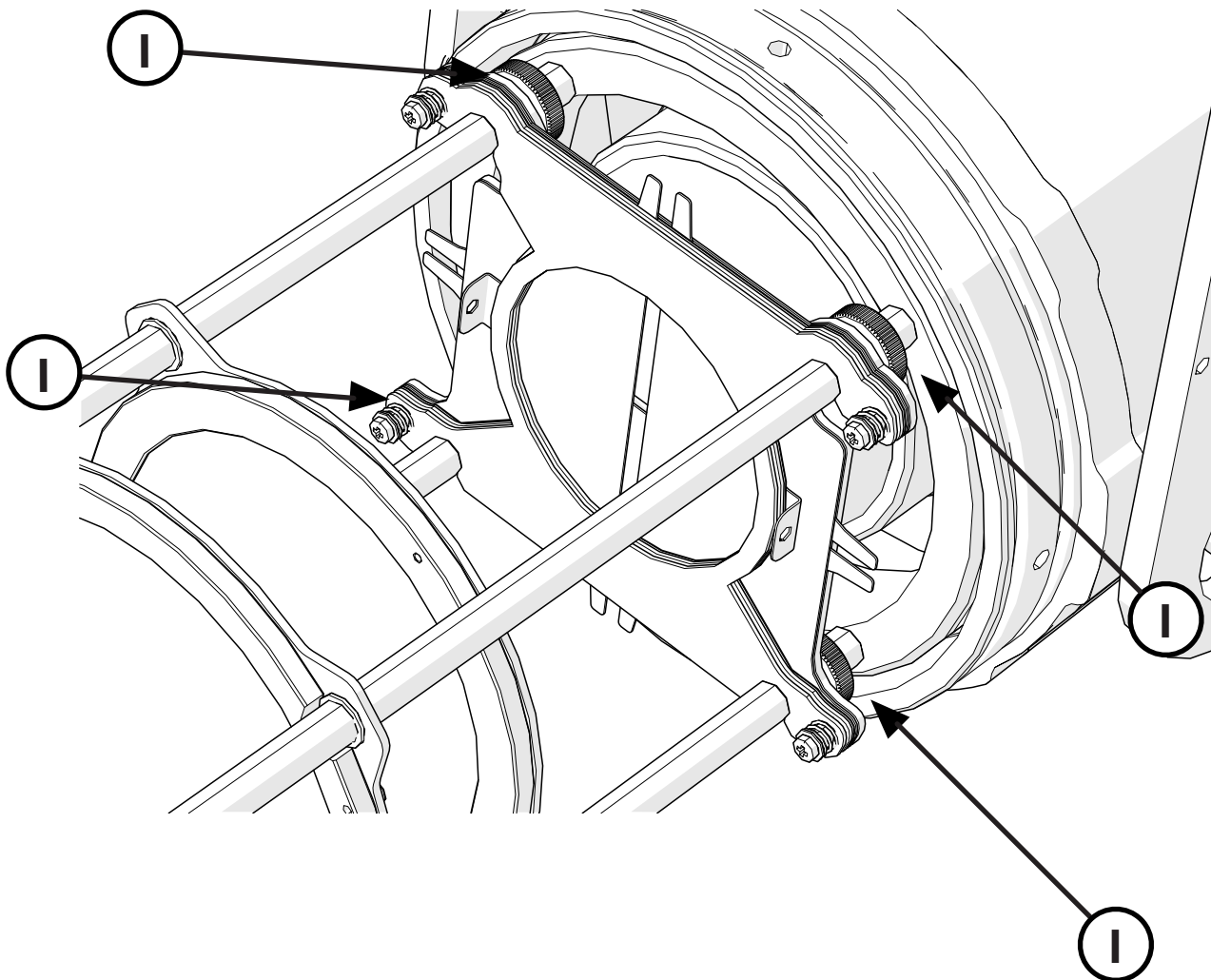

8. Use the hole that you can see above and under the projectors, in it there is a screw and by unscrewing it you can adjust the optical group's position by rotating it, tighten the two screws symmetrically with each other in order to keep straight your optical group;

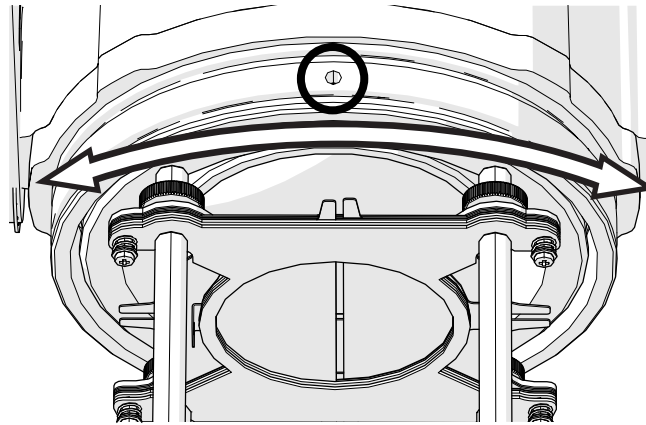

9. Reassemble the projector by pushing the optical holder tube on the optical group and tighten the screws that has been removed at the beginning.

NB: When putting the screws, be careful not to tighten too much, otherwise it may deform the base of the optical holder tube.

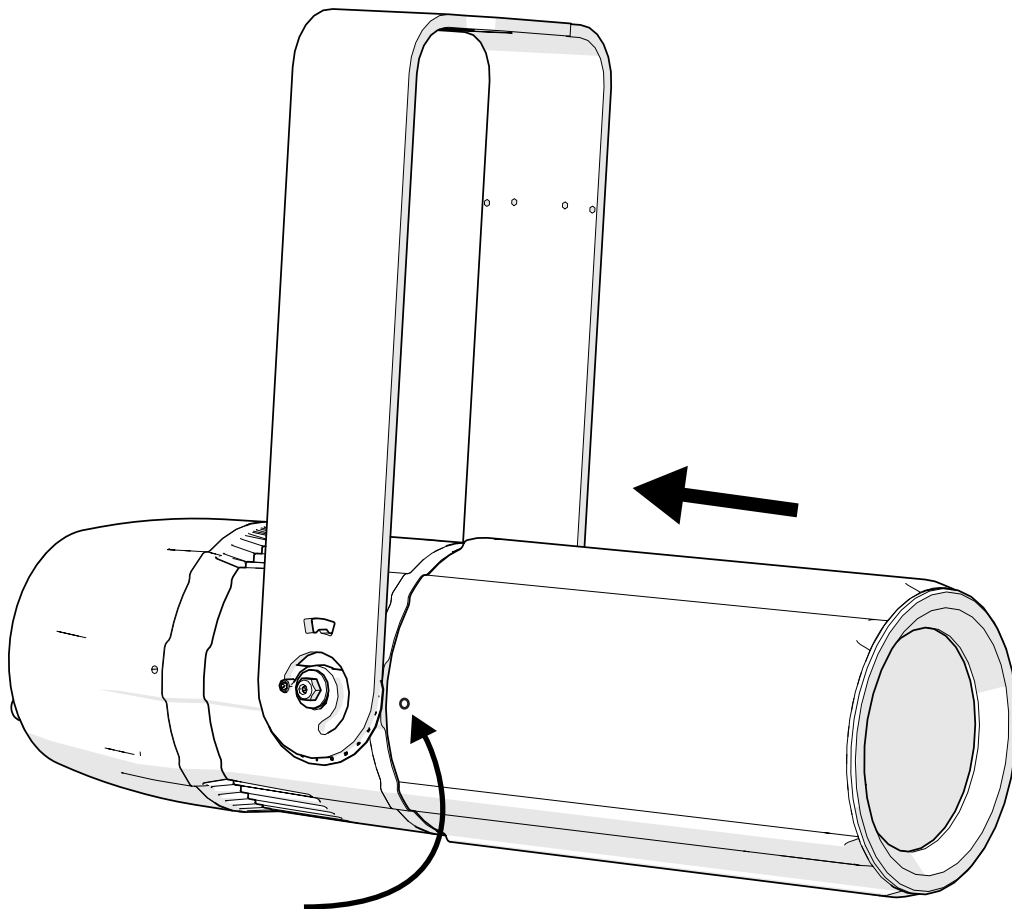

4.5 How to insert a metal gobo

To insert a metal gobo, loosen the four thumb screws "J", insert the gobo in the frontal holder and tighten the thumb screws.

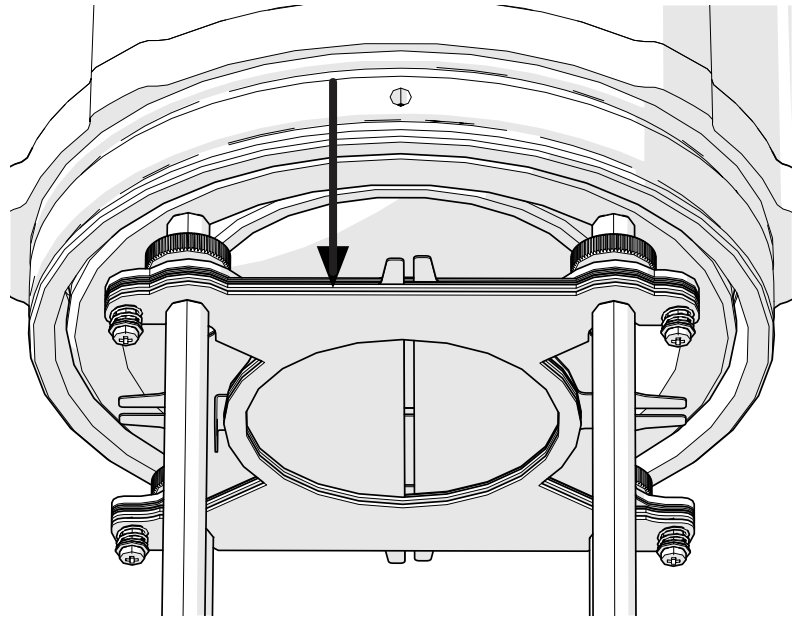
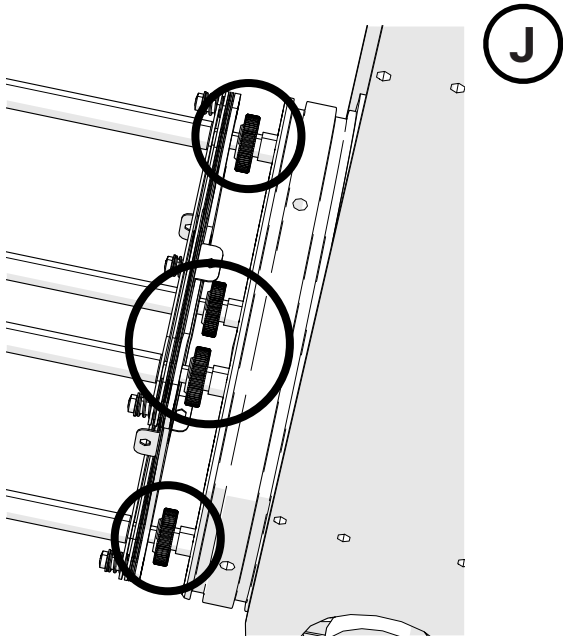

4.6 How to insert a glass gobo

It is possible to insert a glass gobo, to do so unscrew the thumb screws “**K**”, at this point it will be possible to extract the gobo holder “**L**”. Insert the gobo by loosening the 4 screws “**M**”, at this point we suggest you to unscrew completely 2 of them on one side in order to lift the gobo holder and insert the desired glass gobo “**N**”. Once done, screw all the 4 screws and reinsert the gobo holder and retighten the thumb screws.

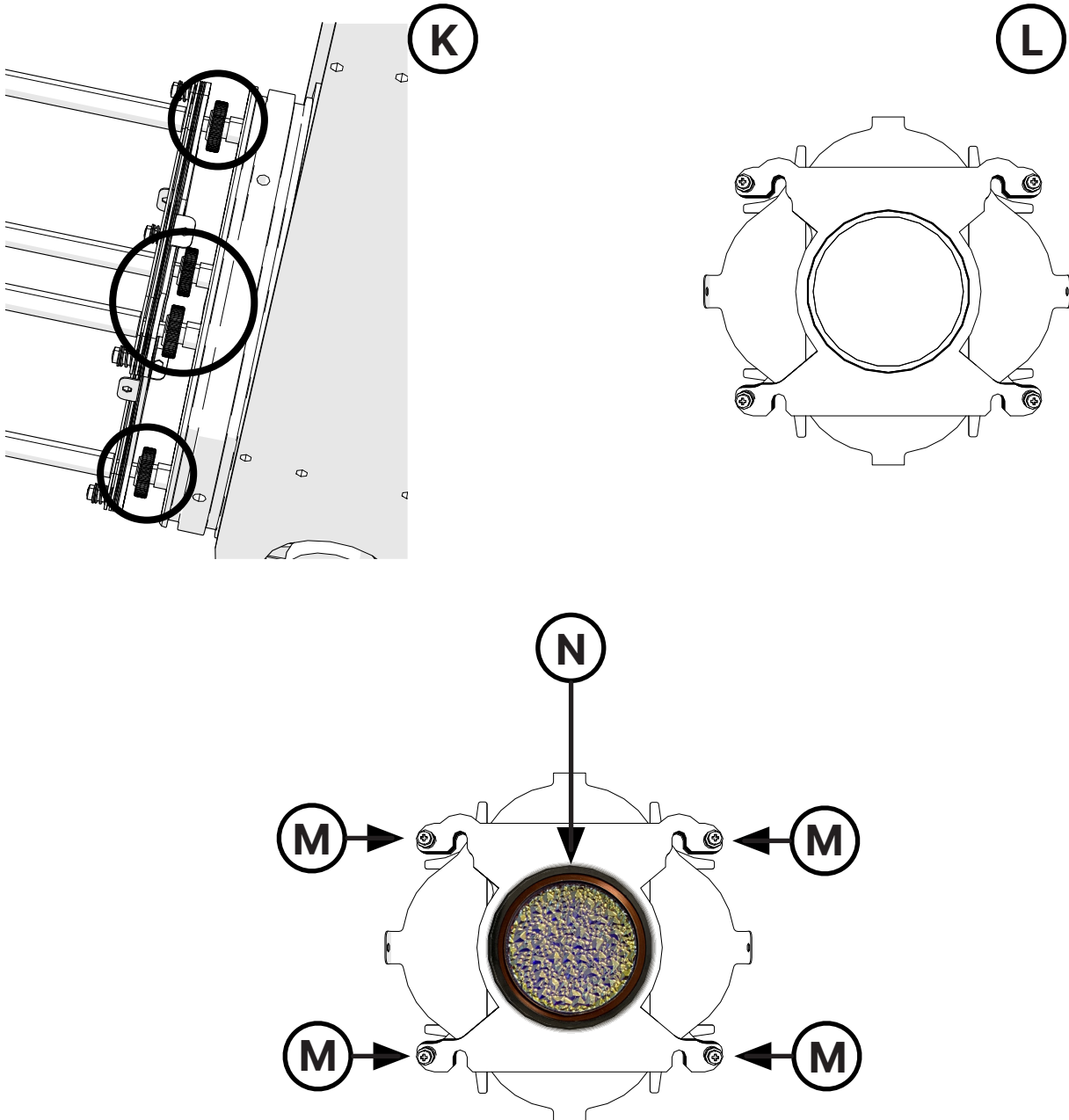

5. Powering up

5.1 Operating voltage and frequency

The unit may operate at voltage ranges from 90 to 230 V at a frequency of 50 or 60 Hz. It is not needed to effect any setup procedures: **LEDko EXT FS RGBLA +** will automatically adjust its operation to suit any frequency or voltage within this range.

5.2 Connection to mains power

Mains cable characteristics

The mains cable provided that comes out from the projector's power box (**30 cm. length**) is thermally resistant, complying to the most recent International standards.

Note: in case of cable replacement, similar cable with comparable thermal resistant qualities must be used exclusively (cable 3 X 1,5 \varnothing external 10 mm, rated 300/500V, tested to 2 KV, operating temperature -40°C + 180°C, Coemar cod. CV5311).

Connection to mains power

LEDko EXT FS RGBLA + is equipped with one **Power Junction Connectors**. Use this connector to connect the cable that comes out from the projector's power box with a cable that you will use to connect to the mains power.

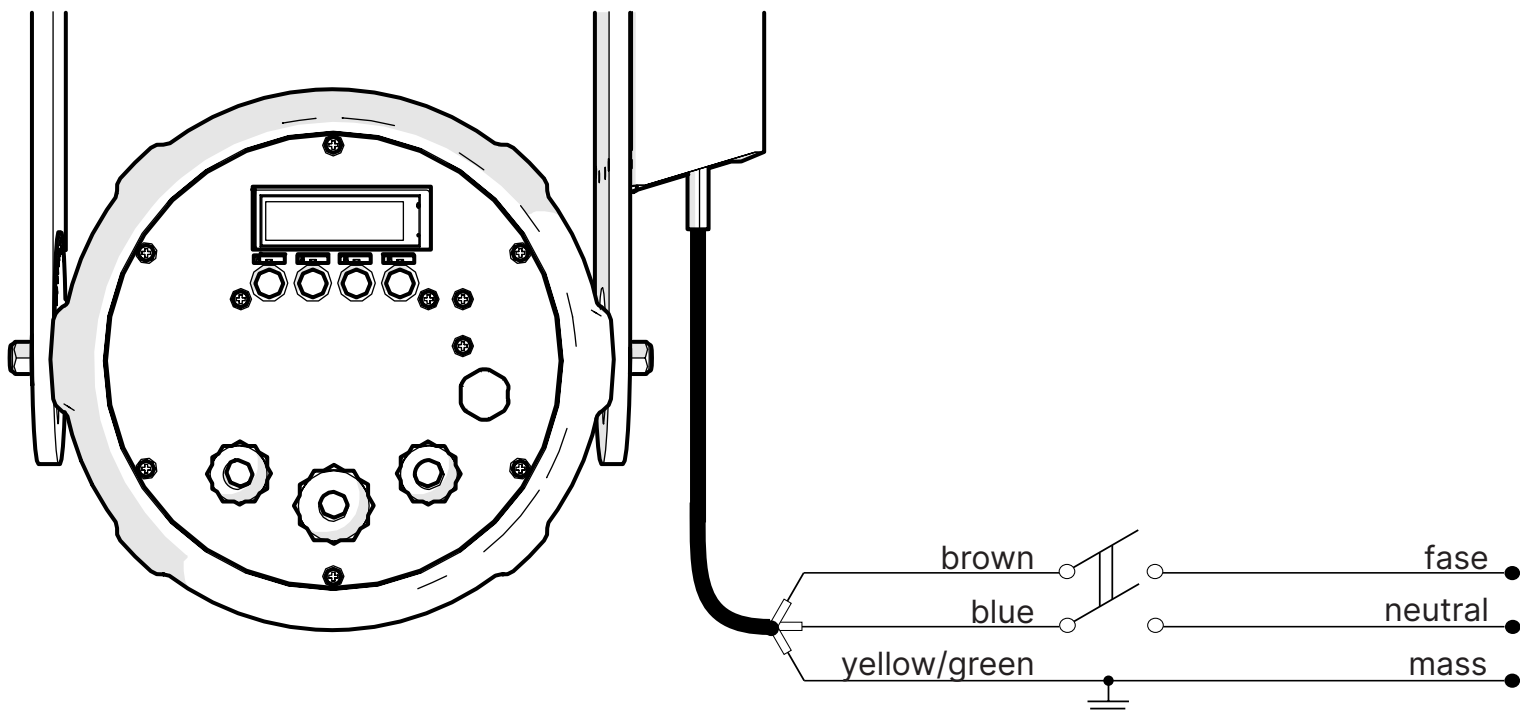

5.3 How to connect the Power Junction Connectors

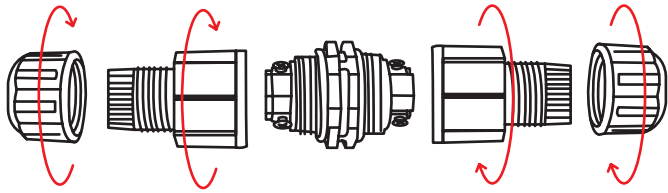

1. Unscrew the left cable gland and right cable gland.

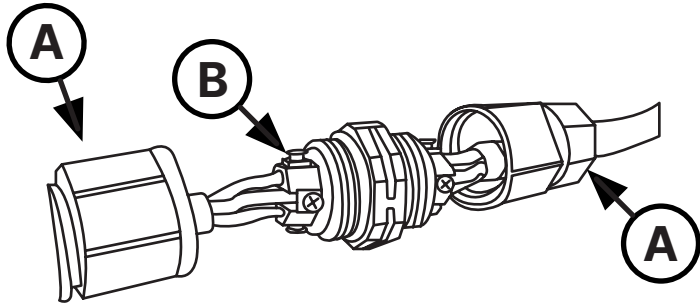

2. Insert the electric cables through the cable glands "A", tighten the wires inside the Pins "B" by screwdriver.

N.B. In order to make the product work properly it is important to connect the cables following the diagram below:

Brass color Pin > Blue (neutral)

Argent color Pin > Yellow/green (mass) \perp

Black color Pin > Brown (fase)

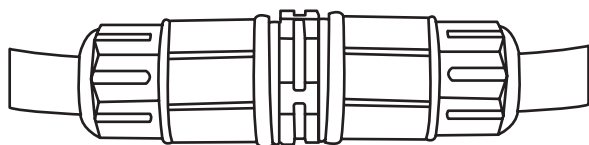

3. Screw the both cable gland tightly (tighten is very important for waterproof).

Warning!!

The use of a thermal/magnetic circuit breaker is recommended. Strict adherence to regulatory norms is strongly recommended.

LEDko EXT FS RGBLA + should not be powered through a dimmer as this may damage the internal switching power supply.

Prior to connecting the device to mains power, ensure that the mains characteristics are within the recommended range for the use of **LEDko EXT FS RGBLA +**.

All cabling and connections should be carried out by a suitably qualified personnel.

6. Control signal connections

6.1 Control signal connection by IP67 Junction Connectors

Important! Protect all connections and all breaks in cable jackets from moisture or water.

The moisture or the water can cause corrosion in unprotected cable connections. They can also be along the inside of cables at breaks or cuts in the cable jacket (for example at connection points) and into fixtures because of the vacuum effect of temperature fluctuations inside fixtures.

To protect connections and fixtures from moisture or water, use the Junction connectors that are protected to IP67 or higher.

To connect them follow the instruction below:

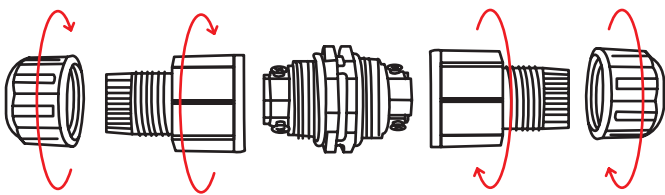

1. Unscrew the left cable gland and right cable gland.

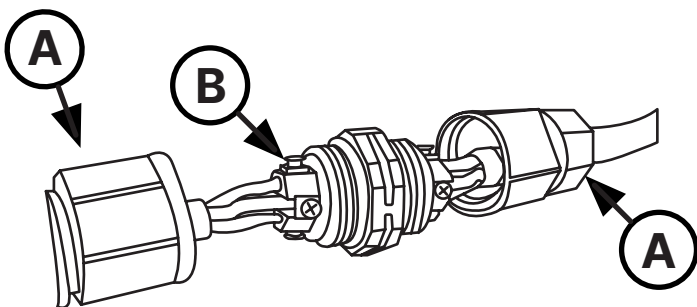

2. Insert the electric cables through the cable glands "A", tighten the wires inside the Pins "B" by screwdriver.

N.B. In order to make the product work properly it is important to connect the cables following the diagram below:

Pin 1 > Ground Wire

Pin 2 > Black Wire (negative)

Pin 3 > White Wire (positive)

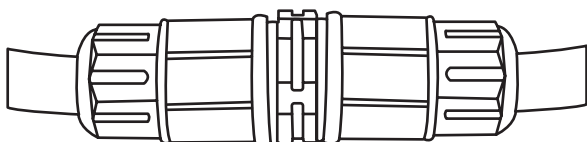

3. Screw the both cable gland tightly (tighten is very important for waterproof).

4. To connect two or more products in series, follow the diagram below.

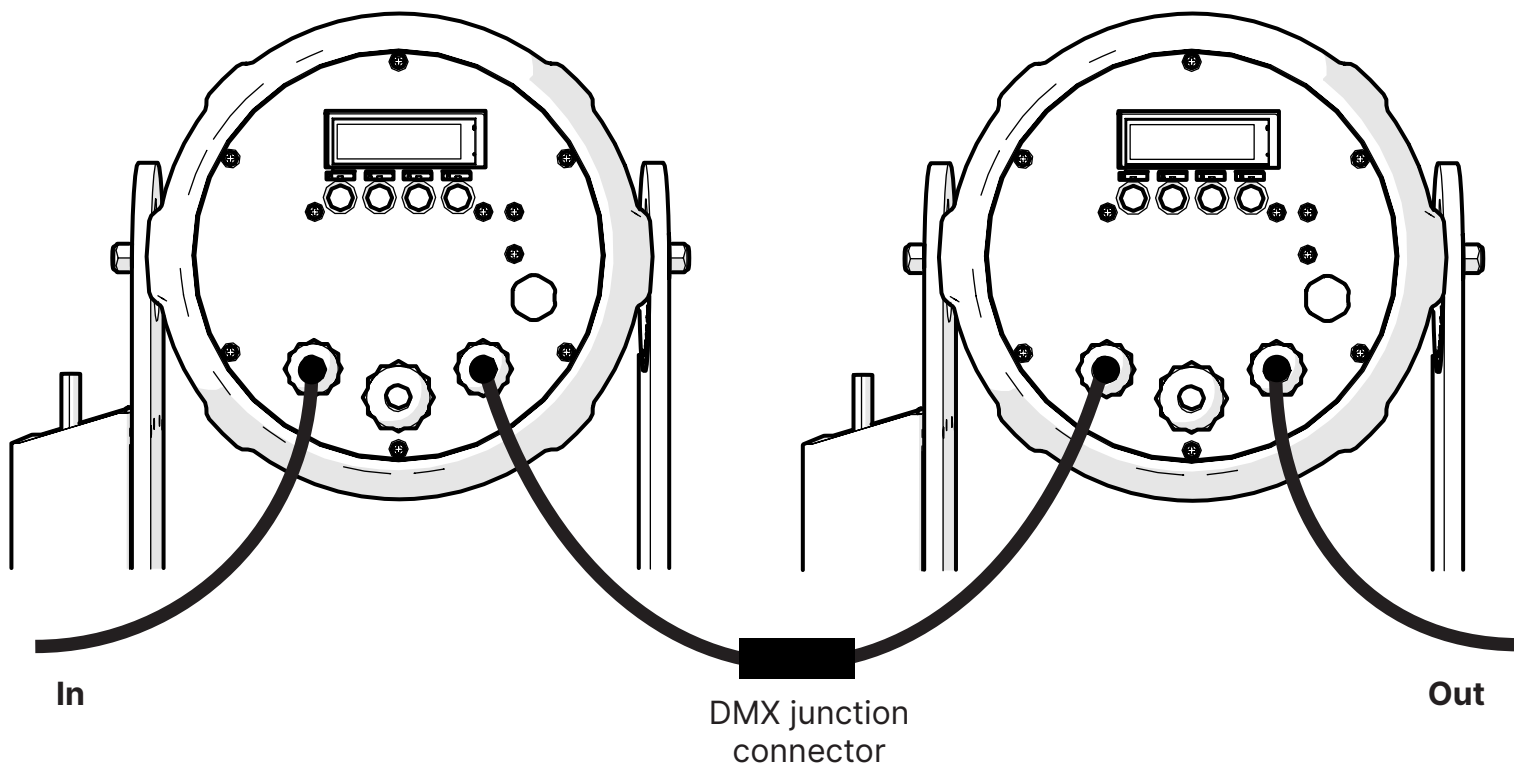

Note: Once the connection of the line is completed use the DMX end of line closure cap (RME34/G), indispensable for the last projector of the line.

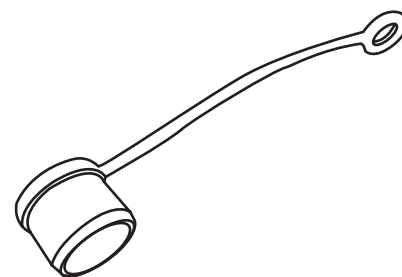

7. Turning the projector on

After having followed the preceding steps described, proceed with the power supply and turn on the projector connecting it to the mains power.

The software version installed on the internal microprocessors will be shown on the display, suddenly it will show the current DMX addressing. If the address blinks, it means that the DMX signal has not been received. Check the connection cable and the mixer functioning.

7.1 DMX address of the unit

Each projector can use **16, 7, 1, Studio, RGB, fine RGB** or **Sunrise modes** address channels for its complete operation and is controlled by a DMX 512 signal.

DMX addressing





When powered up initially, each projector will show "A001", which indicates that the fixture will start responding from the first DMX channel; **LEDko EXT FS RGBLA +** also uses 16 DMX channels, which means that it will respond to the commands from channel 1 to channel 16 of your DMX 512 controller. Accordingly a second unit should be addressed as A017, a third one as A033 and so on. The operation must be carried out on every **LEDko EXT FS RGBLA +** which has an address different from A001.

Altering the DMX address:

1. Press the + or – button until the display shows the required DMX address. The digits on the display will blink to indicate that the variation has not been registered.
2. Press the enter key to confirm your selection. The digits on the display panel will cease to blink and the projector will now respond to the new address.

Note: by holding the + or – button down the scrolling will be faster; thus allowing a faster selection.



-  It means the projector has entered protection
-  It means there is an error, it flashes intermittently with address
-  Wireless Enabled
-  The keys are locked

8. DMX chart

8.1 DMX modes

DMX channels ↓	16 channels	7 channels	1 channel	Studio mode	RGB mode	fine RGB mode	Sunrise mode
1	Master Dimmer	Master Dimmer	Master Dimmer	Master Dimmer	Master Dimmer	Master Dimmer	Master Dimmer
2	Red	Red		White Tone	Dimmer Fine	Dimmer Fine	Dimmer Fine
3	Green	Green		Green Saturation	Red	Red	Proportional CCT
4	Blue	Blue		Saturation	Green	Red Fine	Step CCT
5	Spare Channel	Spare Channel		Hue	Blue	Green	Green Saturation
6	Lime	Lime		Dimmer Fine	White Tone	Green Fine	Special Function
7	Amber	Amber		Special Function	Saturation	Blue	
8	Strobe Effect				Strobe Effect	Blue Fine	
9	Dimmer Fine				Special Function	White Tone	
10	Special Function					Saturation	
11	Red Tone					Strobe Effect	
12	Green Tone					Special Function	
13	Blue Tone						
14	White Tone						
15	Green Saturation						
16	Saturation						

8.2 DMX Chart 16, 7, 1 channels

channel			function	type of control	effect	decimal		percentage	
16	7	1							
1	1	1 ²	master dimmer	proportional	adjust luminous output intensity from 0 to 100%	0	- 255	0%	- 100%
2	2	-	red	proportional	proportional control of the color percentage from 0 % to 100 %	0	- 255	0%	- 100%
3	3	-	green	proportional	proportional control of the color percentage from 0 % to 100 %	0	- 255	0%	- 100%
4	4	-	blue	proportional	proportional control of the color percentage from 0 % to 100 %	0	- 255	0%	- 100%
5	5	-	spare channel	step	no effect	0	- 255	0%	- 100%
6	6	-	lime	proportional	proportional control of the color percentage from 0 % to 100 %	0	- 255	0%	- 100%
7	7	-	amber	proportional	proportional control of the color percentage from 0 % to 100 %	0	- 255	0%	- 100%
8	-	-	strobe effect	step	no effect	0	- 9	0%	- 4%
				proportional	variable speed strobe effect, from slow to fast	10	- 57	4%	- 22%
				step	stop strobe	58	- 59	23%	- 23%
				proportional	sequenced pulse effect, slow closing, fast opening (variable speed pulsing, from slow to fast)	60	- 108	24%	- 42%
				step	stop strobe	109	- 110	43%	- 43%
				proportional	sequenced pulse effect, fast closing, slow opening (variable speed pulsing, from slow to fast)	111	- 159	44%	- 62%
				step	stop strobe	160	- 161	63%	- 63%
				proportional	random strobe effect with variable speed from slow to fast	162	- 207	64%	- 81%
				step	stop strobe	208	- 209	82%	- 82%
				proportional	random strobe effect with variable speed from slow to fast	210	- 255	82%	- 100%
9	-	-	dimmer fine	proportional	fine dimmer control 16 bit	0	- 255	0%	- 100%
10	-	-	special functions	step	park	0	- 9	0%	- 4%
					no effect	10	- 84	4%	- 33%
					fan at SILENT mode	85	- 96	33%	- 38%
					fan at STUDIO mode	97	- 108	38%	- 42%
					fan at AUTO mode	109	- 120	43%	- 47%
				proportional	fan speed control	121	- 133	47%	- 52%
				step	enables the automatic display blackout	134	- 185	53%	- 73%
					disables the automatic display blackout	186	- 199	73%	- 78%
no effect	200	- 255	78%		- 100%				

11'	-	-	red tone	step	no effect	0	-	9	0%	-	4%
					COR01 - GELS RED 1	10	-	34	4%	-	13%
					COR02 - GELS RED 2	35	-	59	14%	-	23%
					COR03 - GELS RED 3	60	-	84	24%	-	33%
					COR04 - GELS RED 4	85	-	109	33%	-	43%
					COR05 - GELS RED 5	110	-	134	43%	-	53%
					COR06 - GELS RED 6	135	-	159	53%	-	62%
					COR07 - GELS RED 7	160	-	184	63%	-	72%
					COR08 - GELS RED 8	185	-	209	73%	-	82%
					COR09 - GELS RED 9	210	-	234	82%	-	92%
					COR10 - GELS RED 10	235	-	255	92%	-	100%
12'	-	-	green tone	step	no effect	0	-	9	0%	-	4%
					COR01 - GELS RED 1	10	-	34	4%	-	13%
					COR02 - GELS RED 2	35	-	59	14%	-	23%
					COR03 - GELS RED 3	60	-	84	24%	-	33%
					COR04 - GELS RED 4	85	-	109	33%	-	43%
					COR05 - GELS RED 5	110	-	134	43%	-	53%
					COR06 - GELS RED 6	135	-	159	53%	-	62%
					COR07 - GELS RED 7	160	-	184	63%	-	72%
					COR08 - GELS RED 8	185	-	209	73%	-	82%
					COR09 - GELS RED 9	210	-	234	82%	-	92%
					COR10 - GELS RED 10	235	-	255	92%	-	100%
13'	-	-	blue tone	step	no effect	0	-	9	0%	-	4%
					COB01 - GELS BLUE 1	10	-	34	4%	-	13%
					COB02 - GELS BLUE 2	35	-	59	14%	-	23%
					COB03 - GELS BLUE 3	60	-	84	24%	-	33%
					COB04 - GELS BLUE 4	85	-	109	33%	-	43%
					COB05 - GELS BLUE 5	110	-	134	43%	-	53%
					COB06 - GELS BLUE 6	135	-	159	53%	-	62%
					COB07 - GELS BLUE 7	160	-	184	63%	-	72%
					COB08 - GELS BLUE 8	185	-	209	73%	-	82%
					COB09 - GELS BLUE 9	210	-	234	82%	-	92%
					COB10 - GELS BLUE 10	235	-	255	92%	-	100%
14	-	-	white tone	step	no effect	0	-	9	0%	-	4%
					2.700 K	10	-	15	4%	-	6%
				proportional	proportional value from 2.700 K to 3.200 K	16	-	30	6%	-	12%
				step	3.200 K	31	-	45	12%	-	18%
				proportional	proportional value from 3.200 K to 4.000 K	46	-	60	18%	-	24%
				step	4.000 K	61	-	75	24%	-	29%
				proportional	proportional value from 4.000 K to 5.000 K	76	-	90	30%	-	35%
				step	5.000 K	91	-	105	36%	-	41%
				proportional	proportional value from 5.000 K to 5.600 K	106	-	120	42%	-	47%
				step	5.600 K	121	-	135	47%	-	53%
				proportional	proportional value from 5.600 K to 7.000 K	136	-	150	53%	-	59%
				step	7.000 K	151	-	165	59%	-	65%
				proportional	proportional value from 7.000 K to 8.000 K	166	-	180	65%	-	71%
				step	8.000 K	181	-	195	71%	-	76%
				proportional	proportional value from 8.000 K to 9.000 K	196	-	210	77%	-	82%
step	9.000 K	211	-	225	83%	-	88%				
proportional	proportional value from 9.000 K to 10.000 K	226	-	240	89%	-	94%				
step	10.000 K	241	-	255	95%	-	100%				

15 ³	-	-	green saturation	step	no effect	0	0%
				proportional	exalts the green color in the mixing and diminishes the presence of magenta	1 - 127	0% - 50%
				step	no effect	128	50%
				proportional	diminishes the presence of green in the mixing and exalts the magenta color	129 - 254	51% - 99%
				step	no effect	255	100
16 ⁴	-	-	saturation	proportional	the white tone fades to the tone built with the RGBCLA channels	0 - 255	0% - 100%

Note 1: channels involving 11 - 12 - 13 macro colors can also be obtained by mixing channels 2 - 3 - 4 - 5 - 6 - 7.

Note 2: the one channel function mode can be selected through the "DMX SETTINGS" menu.

Note 3: the rest position of the green saturation is 128. Diminishing the DMX value augments the presence of the green color. Increasing the DMX value augments the presence of magenta.

Note 4: increasing the value of the saturation DMX channel the white tone (channel 14) will fade to the color selected by the channel 2 - 3 - 4 - 5 - 6 - 7.

Projector: LEDko EXT FullSpectrum RGBLA + Edition: 1	Chart name: DMX512 function	software version: 0.76 or following
--	-----------------------------	-------------------------------------

8.3 DMX Chart Studio Mode

channel	function	type of control	effect	decimal	percentage
1	master dimmer	proportional	adjust luminous output intensity from 0 to 100%	0 - 255	0% - 100%
2	white tone	step	2.700 K	0 - 15	0% - 6%
		proportional	proportional value from 2.700 K to 3.200 K	16 - 30	6% - 12%
		step	3.200 K	31 - 45	12% - 18%
		proportional	proportional value from 3.200 K to 4.000 K	46 - 60	18% - 24%
		step	4.000 K	61 - 75	24% - 29%
		proportional	proportional value from 4.000 K to 5.000 K	76 - 90	30% - 35%
		step	5.000 K	91 - 105	36% - 41%
		proportional	proportional value from 5.000 K to 5.600 K	106 - 120	42% - 47%
		step	5.600 K	121 - 135	47% - 53%
		proportional	proportional value from 5.600 K to 7.000 K	136 - 150	53% - 59%
		step	7.000 K	151 - 165	59% - 65%
		proportional	proportional value from 7.000 K to 8.000 K	166 - 180	65% - 71%
		step	8.000 K	181 - 195	71% - 76%
		proportional	proportional value from 8.000 K to 9.000 K	196 - 210	77% - 82%
step	9.000 K	211 - 225	83% - 88%		
proportional	proportional value from 9.000 K to 10.000 K	226 - 240	89% - 94%		
step	10.000 K	241 - 255	95% - 100%		
3 ¹	green saturation	step	no effect	0	0%
		proportional	exalts the green color in the mixing and diminishes the presence of magenta	1 - 127	0% - 50%
		step	no effect	128	50%
		proportional	diminishes the presence of green in the mixing and exalts the green color	129 - 254	51% - 99%
		step	no effect	255	100%
4	saturation	proportional	the white tone fades to the tone built with the HUE channel	0 - 255	0% - 100%
5 ²	hue	proportional	reproduce the color crossfades around the color space	0 - 255	0% - 100%
6	dimmer fine	proportional	fine dimmer control 16 bit	0 - 255	0% - 100%
7	special functions	step	park	0 - 9	0% - 4%
			no effect	10 - 84	4% - 33%
			fan at SILENT mode	85 - 96	33% - 38%
			fan at STUDIO mode	97 - 108	38% - 42%
			fan at AUTO mode	109 - 120	43% - 47%
		proportional	fan speed control	121 - 133	47% - 52%
		step	enables the automatic display blackout	134 - 185	53% - 73%
			disables the automatic display blackout	186 - 199	73% - 78%
			no effect	200 - 255	78% - 100%

Note 1: the rest position of the green saturation is 128. Diminishing the DMX value augments the presence of the green color. Increasing the DMX value augments the presence of magenta.

Note 2: increasing the value of the saturation DMX channel (channel 4) the white light will fade to the color selected with the HUE channel (channel 5)

Projector: LEDko EXT FullSpectrum RGBLA + Edition: 1	Chart name: DMX512 function	software version: 0.76 or following
--	-----------------------------	-------------------------------------

8.4 DMX Chart RGB Mode

channel	function	type of control	effect	decimal	percentage
1	master dimmer	proportional	adjust luminous output intensity from 0 to 100%	0 - 255	0% - 100%
2	dimmer fine	proportional	fine dimmer control 16 bit	0 - 255	0% - 100%
3	red	proportional	proportional control of the color percentage from 0 % to 100 %	0 - 255	0% - 100%
4	green	proportional	proportional control of the color percentage from 0 % to 100 %	0 - 255	0% - 100%
5	blue	proportional	proportional control of the color percentage from 0 % to 100 %	0 - 255	0% - 100%
6	white tone	step	no effect	0 - 9	0% - 4%
		step	2.700 K	10 - 15	4% - 6%
		proportional	proportional value from 2.700 K to 3.200 K	16 - 30	6% - 12%
		step	3.200 K	31 - 45	12% - 18%
		proportional	proportional value from 3.200 K to 4.000 K	46 - 60	18% - 24%
		step	4.000 K	61 - 75	24% - 29%
		proportional	proportional value from 4.000 K to 5.000 K	76 - 90	30% - 35%
		step	5.000 K	91 - 105	36% - 41%
		proportional	proportional value from 5.000 K to 5.600 K	106 - 120	42% - 47%
		step	5.600 K	121 - 135	47% - 53%
		proportional	proportional value from 5.600 K to 7.000 K	136 - 150	53% - 59%
		step	7.000 K	151 - 165	59% - 65%
		proportional	proportional value from 7.000 K to 8.000 K	166 - 180	65% - 71%
		step	8.000 K	181 - 195	71% - 76%
		proportional	proportional value from 8.000 K to 9.000 K	196 - 210	77% - 82%
		step	9.000 K	211 - 225	83% - 88%
proportional	proportional value from 9.000 K to 10.000 K	226 - 240	89% - 94%		
step	10.000 K	241 - 255	95% - 100%		
7 ¹	saturation	proportional	the white tone fades to the tone built with the RGB channels	0 - 255	0% - 100%
8	strobe effect	step	no effect	0 - 9	0% - 4%
		proportional	variable speed strobing effect, from slow to fast	10 - 57	4% - 22%
		step	stop strobe	58 - 59	23% - 23%
		proportional	sequenced pulse effect, slow closing, fast opening (variable speed pulsing, from slow to fast)	60 - 108	24% - 42%
		step	stop strobe	109 - 110	43% - 43%
		proportional	sequenced pulse effect, fast closing, slow opening (variable speed pulsing, from slow to fast)	111 - 159	44% - 62%
		step	stop strobe	160 - 161	63% - 63%
		proportional	random strobe effect with variable speed from slow to fast	162 - 207	64% - 81%
		step	stop strobe	208 - 209	82% - 82%
proportional	random strobe effect with variable speed from slow to fast	210 - 255	82% - 100%		

9	special functions	step	park	0 - 9	0% - 4%
			no effect	10 - 84	4% - 33%
			fan at SILENT mode	85 - 96	33% - 38%
			fan at STUDIO mode	97 - 108	38% - 42%
			fan at AUTO mode	109 - 120	43% - 47%
		proportional	fan speed control	121 - 133	47% - 52%
		step	enables the automatic display blackout	134 - 185	53% - 73%
			disables the automatic display blackout	186 - 199	73% - 78%
			no effect	200 - 255	78% - 100%

Note 1: increasing the value of the saturation DMX channel the white tone (channel 6) will fade to the color selected by the channel 3, 4 or 5

8.5 DMX Chart fine RGB mode

channel	function	type of control	effect	decimal		percentage	
1	master dimmer	proportional	adjust luminous output intensity from 0 to 100%	0	- 255	0%	- 100%
2	dimmer fine	step	fine dimmer control 16 bit	0	- 255	0%	- 100%
3	red	proportional	proportional control of the color percentage from 0 % to 100 %	0	- 255	0%	- 100%
4	red fine	step	fine red control 16 bit	0	- 255	0%	- 100%
5	green	proportional	proportional control of the color percentage from 0 % to 100 %	0	- 255	0%	- 100%
6	green fine	step	fine green control 16 bit	0	- 255	0%	- 100%
7	blue	proportional	proportional control of the color percentage from 0 % to 100 %	0	- 255	0%	- 100%
8	blue fine	step	fine blue control 16 bit	0	- 255	0%	- 100%
9	white tone	step	no effect	0	- 9	0%	- 4%
			2.700 K	10	- 15	4%	- 6%
		proportional	proportional value from 2.700 K to 3.200 K	16	- 30	6%	- 12%
		step	3.200 K	31	- 45	12%	- 18%
		proportional	proportional value from 3.200 K to 4.000 K	46	- 60	18%	- 24%
		step	4.000 K	61	- 75	24%	- 29%
		proportional	proportional value from 4.000 K to 5.000 K	76	- 90	30%	- 35%
		step	5.000 K	91	- 105	36%	- 41%
		proportional	proportional value from 5.000 K to 5.600 K	106	- 120	42%	- 47%
		step	5.600 K	121	- 135	47%	- 53%
		proportional	proportional value from 5.600 K to 7.000 K	136	- 150	53%	- 59%
		step	7.000 K	151	- 165	59%	- 65%
		proportional	proportional value from 7.000 K to 8.000 K	166	- 180	65%	- 71%
		step	8.000 K	181	- 195	71%	- 76%
		proportional	proportional value from 8.000 K to 9.000 K	196	- 210	77%	- 82%
step	9.000 K	211	- 225	83%	- 88%		
proportional	proportional value from 9.000 K to 10.000 K	226	- 240	89%	- 94%		
step	10.000 K	241	- 255	95%	- 100%		
10 ¹	saturation	proportional	the white tone fades to the tone built with the RGB channels	0	- 255	0%	- 100%
11	strobe	step	no effect	0	- 9	0%	- 4%
		proportional	variable speed strobing effect, from slow to fast	10	- 57	4%	- 22%
		step	stop strobe	58	- 59	23%	- 23%
		proportional	sequenced pulse effect, slow closing, fast opening (variable speed pulsing, from slow to fast)	60	- 108	24%	- 42%
		step	stop strobe	109	- 110	43%	- 43%
		proportional	sequenced pulse effect, fast closing, slow opening (variable speed pulsing, from slow to fast)	111	- 159	44%	- 62%
		step	stop strobe	160	- 161	63%	- 63%
		proportional	random strobe effect with variable speed from slow to fast	162	- 207	64%	- 81%
		step	stop strobe	208	- 209	82%	- 82%
		proportional	random strobe effect with variable speed from slow to fast	210	- 255	82%	- 100%

12	special functions	step	park	0	-	9	0%	-	4%
			no effect	10	-	84	4%	-	33%
			fan at SILENT mode	85	-	96	33%	-	38%
			fan at STUDIO mode	97	-	108	38%	-	42%
			fan at AUTO mode	109	-	120	43%	-	47%
		proportional	fan speed control	121	-	133	47%	-	52%
		step	enables the automatic display blackout	134	-	185	53%	-	73%
			disables the automatic display blackout	186	-	199	73%	-	78%
			no effect	200	-	255	78%	-	100%

Note 1: increasing the value of the saturation DMX channel the white tone (channel 6) will fade to the color selected by the channel 3, 4 or 5

Projector: LEDko EXT FullSpectrum RGBLA + Edition: 1	Chart name: DMX512 function	software version: 0.76 or following
--	-----------------------------	-------------------------------------

8.6 DMX Chart SUNRISE mode

channel	function	type of control	effect	decimal	percentage
1	master dimmer	proportional	adjust luminous output intensity from 0 to 100%	0 - 255	0% - 100%
2	dimmer fine	proportional	fine dimmer control 16 bit	0 - 255	0% - 100%
3	proportional cct	proportional	2.700 K	0	0%
			proportional value from 2.700 K to 4000 K	1 - 44	0% - 17%
			4.000 K	45	18%
			proportional value from 4.000 to 5.000 K	46 - 79	18% - 31%
			5.000 K	80	31%
			proportional value from 5.000 to 5.600 K	81 - 100	32% - 39%
			5.600 K	101	40%
			proportional value from 5.600 K to 10.000 K	102 - 254	40% - 100%
			10.000 K	255	100%
4	step cct	step	no effect	0 - 9	0% - 4%
			2.700 K	10 - 36	4% - 14%
			3.200 K	37 - 63	15% - 25%
			4.000 K	64 - 90	25% - 35%
			5.000 K	91 - 117	36% - 46%
			5.600 K	118 - 144	46% - 56%
			7.000 K	145 - 171	57% - 67%
			8.000 K	172 - 198	67% - 78%
			9.000 K	199 - 225	78% - 88%
			10.000 K	226 - 255	89% - 100%
5	green saturation	step	no effect	0	0%
		proportional	exalts the green color in the mixing and diminishes the presence of magenta	1 - 127	0% - 50%
		step	no effect	128	50%
		proportional	diminishes the presence of green in the mixing and exalts the green color	129 - 254	51% - 99%
		step	no effect	255	100%
6	special functions	step	park	0 - 9	0% - 4%
			no effect	10 - 84	4% - 33%
			fan at SILENT mode	85 - 96	33% - 38%
			fan at STUDIO mode	97 - 108	38% - 42%
			fan at AUTO mode	109 - 120	43% - 47%
		proportional	fan speed control	121 - 133	47% - 52%
		step	enables the automatic display blackout	134 - 185	53% - 73%
			disables the automatic display blackout	186 - 199	73% - 78%
			no effect	200 - 255	78% - 100%

Note 1: If channels 3 and 4 are used simultaneously, channel 4 prevails.

Projector: LEDko EXT FullSpectrum RGBLA + Edition: 1	Chart name: DMX512 function	software version: 0.76 or following
--	-----------------------------	-------------------------------------

9. Setup via RDM

9.1 Quick guide to menu

The **LEDko EXT FS RGBLA +** required RDM (Remote Device Management) to set up fixtures. Using an RDM compliant DMX controller, you can communicate with all the fixtures on a data link without needing to connect to each fixture individually. RDM lets you set the DMX addresses of all the fixtures on the link, carry out fixture configuration and retrieve fixture data including details of any error that has been logged. If two or more identical fixtures are set up with the same DMX address and in the same DMX mode, they will receive the same instructions and behave identically. Setting up identical fixtures with the same address is a good tool for troubleshooting unexpected behavior and an easy way to achieve synchronized action. Setting DMX addresses via RDM involves running a scan to identify the fixtures that are present on the data link and then allocating addresses either automatically or manually.

To use RDM:

1. Obtain an RDM-compatible controller such as the RDM UPGRADE INTERFACE B (cod. AC10011A001) application running on a Windows PC.
2. Use a USB cable to connect the PC to a USB/DMX interface box
3. Connect the interface box to the data link.
4. Power the fixture on and carry out an RDM discovery / scan in your RDM-compatible controller.
5. You can then configure or retrieve data from the fixtures on the data link.

9.2 RDM Chart

PARAMETER	DESCRIPTION
DMX ADDRESS	Set DMX Address: (1-512)
CURVE	Set Dimming Curve: Linear, Logarithmic, Exponential, Halogen, Standard
FREQUENCY	Fixed at 20.000 Hz
LOCK PIN	Set Lock Pin
LOCK STATE	Set Screen Lock
FACTORY DEFAULT	Factory Reset
PERSONALITY	Set Personality: 16 / 7 / 1 / Studio mode / RGB mode / fine RGB mode / Sunrise mode
SENSOR	Visualize Sensor
LED HOURS	Visualize Led Life Hours
DEVICE HOURS	Visualize Device Life Hours

9.3 RDM Error Chart

ERROR	DESCRIPTION	SOLUTION
MEMORY	Memory Reading Error	Perform A “Factory Reset”
HW MEMORY	Memory Hardware Error	Contact Coemar
DMX ADDR	DMX Addressing Error	The Personality Dimension Exceeds 512 Channels
NTC ERROR	Temperature Sensor Disconnected	Check Wiring NTC Led
SHORT NTC	Short-Circuited Temperature Sensor	Check Wiring NTC Led
OVER TEMP	Electronic Board Overtemperature	Ambient temperature too high, place the projector in an environment with temperature below 40°C

10. Display panel functions

10.1 Quick guide to menu

To access the functions menus just press the MENU button. Then press + or – buttons to scroll the pages and press the ENTER button to access to any other function.

By suitably using all the functions of **LEDko EXT FS RGBLA +**, which can be activated through its display panel, it is possible to change some of the parameters and to add some functions.

Changing the preset settings made by **Coemar** can vary the functions of the projector so that it will respond differently to the controller; therefore carefully read about the functions described here before carrying out any possible selection.

10.2 Rapid count

Through the display panel of **LEDko EXT FS RGBLA +** it is possible to quickly change the various numbers displayed for the different functions in the following 3 manners:

1. Pressing the + or – buttons will cause the count to be quicker.
2. Pressing first + and then – and then holding them down simultaneously will cause the numbers to jump to the highest value.
3. Pressing first – and then + and then holding them down simultaneously will cause the number to jump to the lowest value.



This will be the first screen that will appear on the display once the projector is turned on. To change the DMX address press the “+” button and chose the DMX address desired.

N.B. If the projector is not connected to the DMX signal, A001 will blink intermittently

10.3 Main functions menu

By pressing the "MENU" button you can enter the **LEDko EXT FS RGBLA +** main menu.

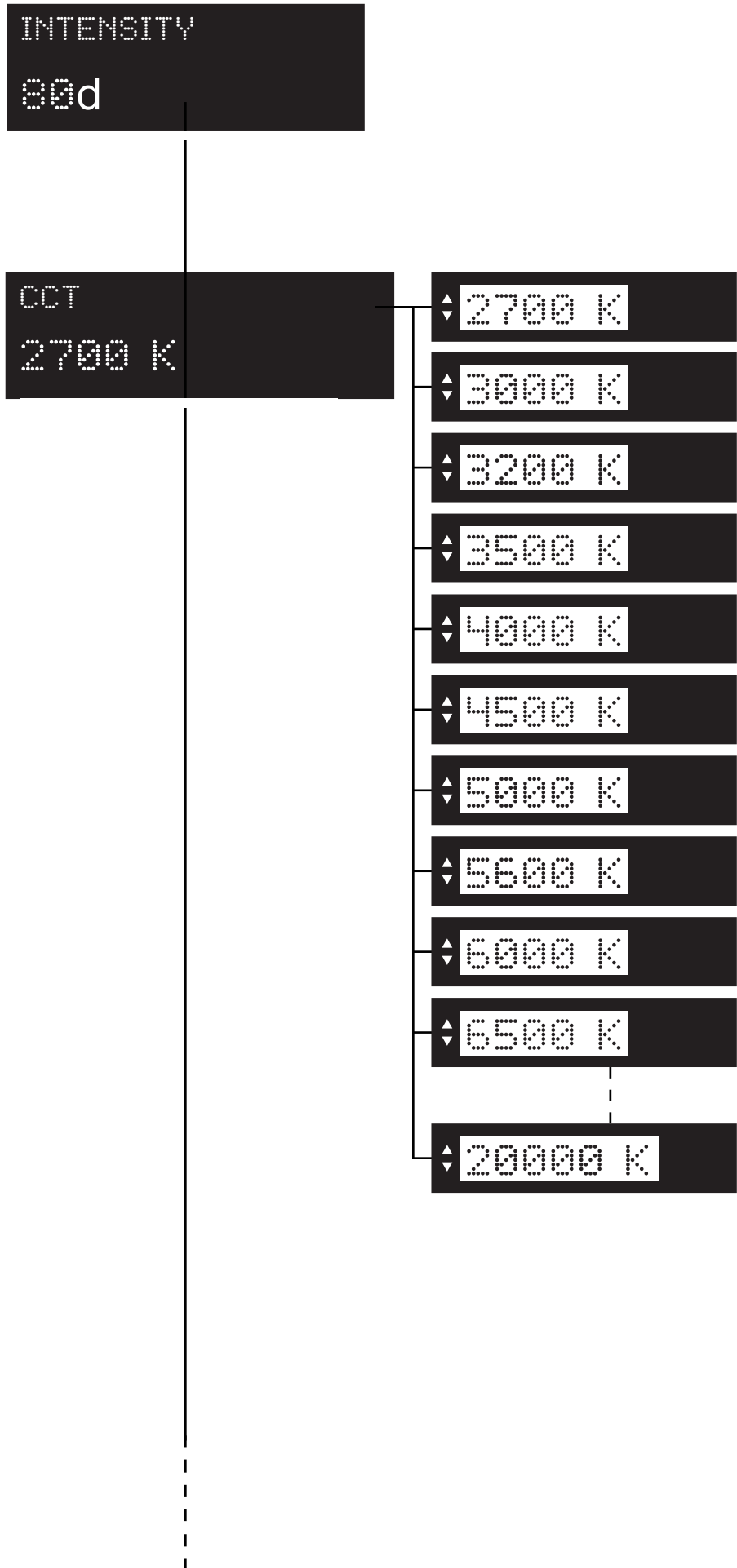

INTENSITY:

Allows to adjust the luminous output intensity from 0 to 255 (d: decimal units).

CCT:

This channel offers a preset library of various white CCT with a range that goes from 2.700 K and up to 20.000 K, manually selectable without the need of a DMX console.

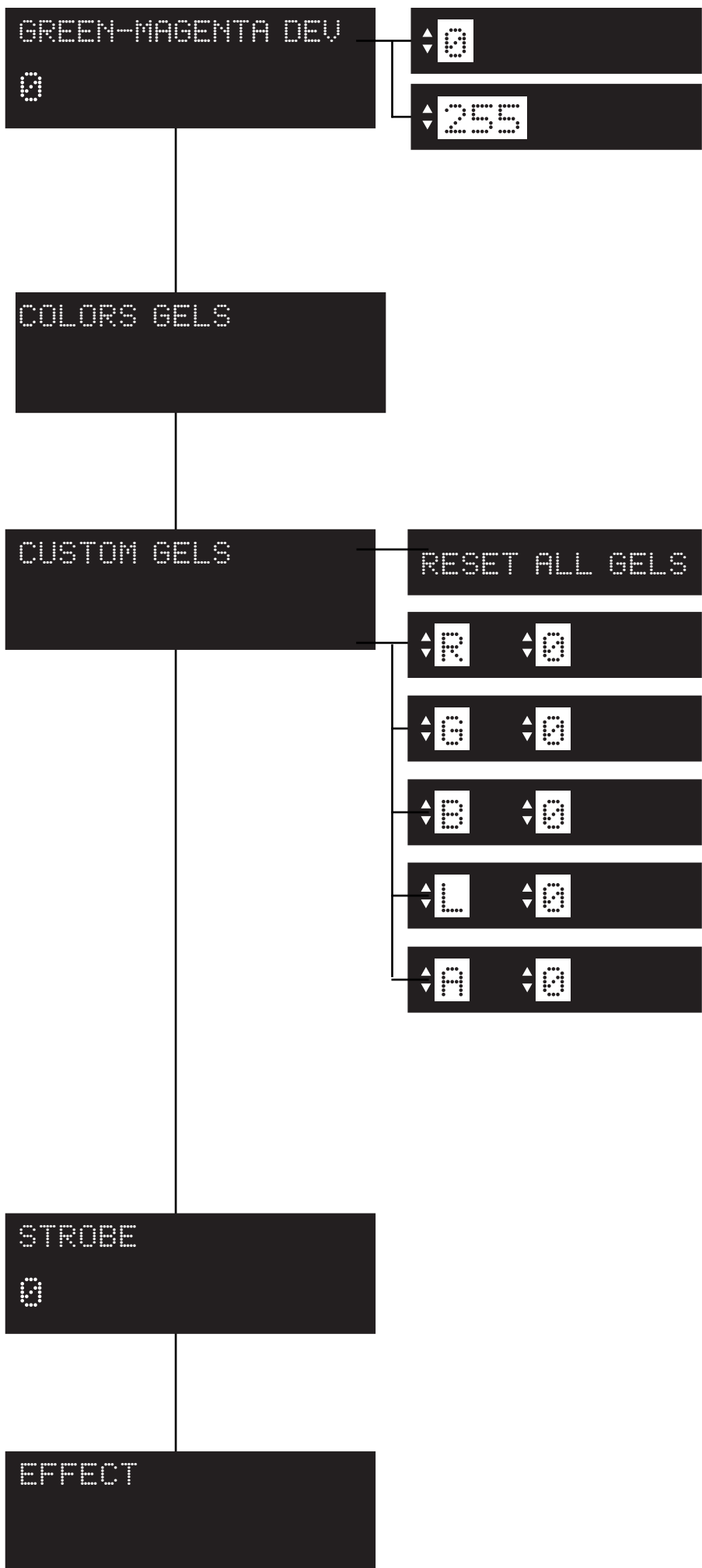

GREEN-MAGENTA DEV:

Allows to adjust the luminous output intensity from 0 to 255 (d: decimal units).

COLOR GELS:

All the gels presets will appear under this menu.

CUSTOM GELS:

This settings allows you to create your own custom gel by mixing the six color at your will. Every color is adjustable from 0 to 255.

STROBE:

Manually sets the strobe DMX channel.

EFFECTS:

Effects settings (section **EFFECTS**).

SETTINGS

MEASURES

FACTORY RESET

SURE?

SETTINGS:

Manually sets various settings of the projector (section **SETTINGS**).

MEASURES:

Check all the measures and product status (section **MEASURES**).

FACTORY RESET:

Allows to return to the factory settings:
Light Intensity: 80
DMX Channels: 16
Fan: Auto mode.

10.4 Settings

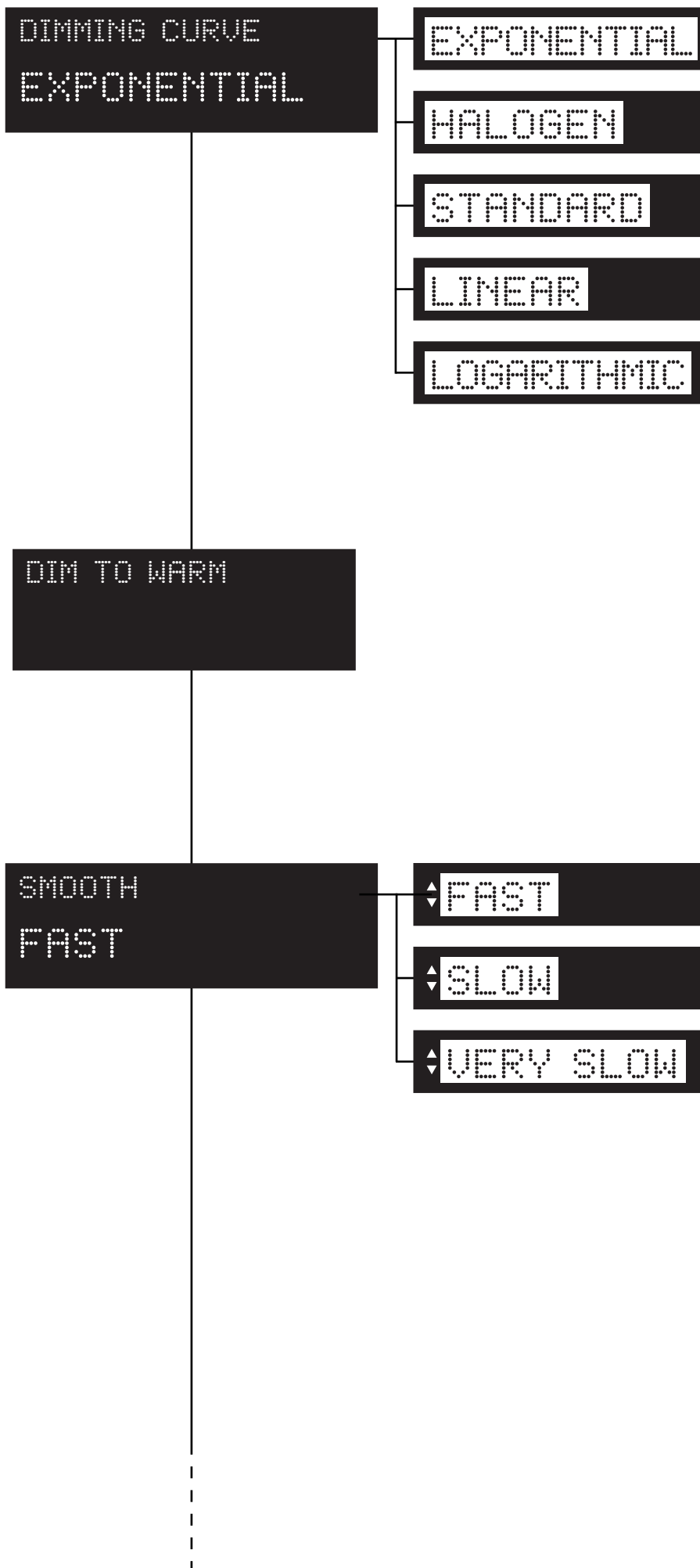

DIMMING CURVE:

It allows the selection of different dimmer curves: exponential (default), halogen, standard, linear and logarithmic.

DIM TO WARM:

Inserts a softening of the dimmer dynamics and red shift. It works for all the CCTs.

SMOOTH:

Allows to change the speed of every dimming curve between **FAST** (standard), **SLOW**, **VERY SLOW**.

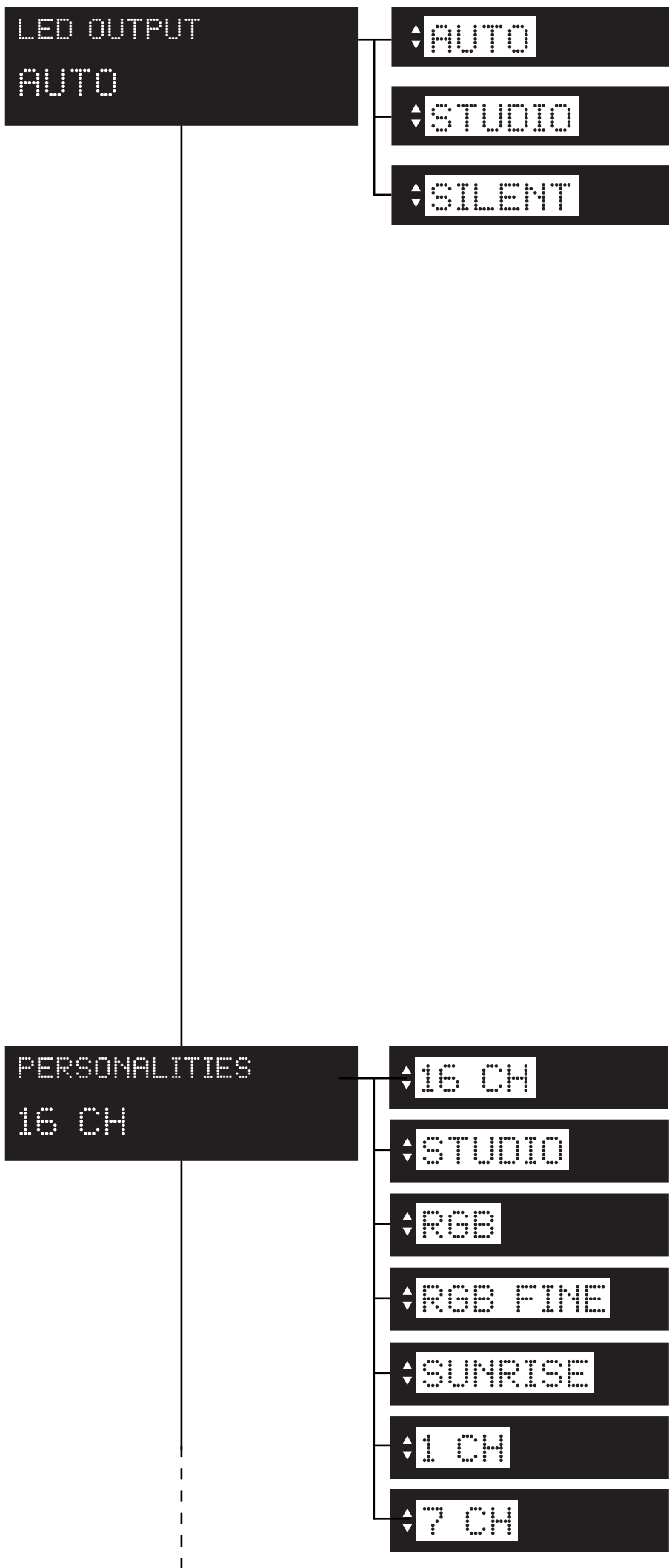

LED OUTPUT:

Manually sets the fan mode.

AUTO: Fan with automatic operating speed to guarantee maximum light output in all conditions of use, ideal for live events, exhibitions and architectural installations.

STUDIO: Fan at automatic operation speed with limited speed to guarantee silent operation of the product (moderately limited light output, will decrease in case of overheat) ideal for broadcast or theatre applications.

SILENT: This setting will keep the speed of the fan at the minimum level (moderately limited light output, will decrease in case of overheat) ideal for environments that require maximum silence.

PERSONALITIES:

It is possible to choose between **16**, **STUDIO**, **RGB**, **RGB FINE**, **SUNRISE**, **1** or **7** modalities, in which the projector will operate.

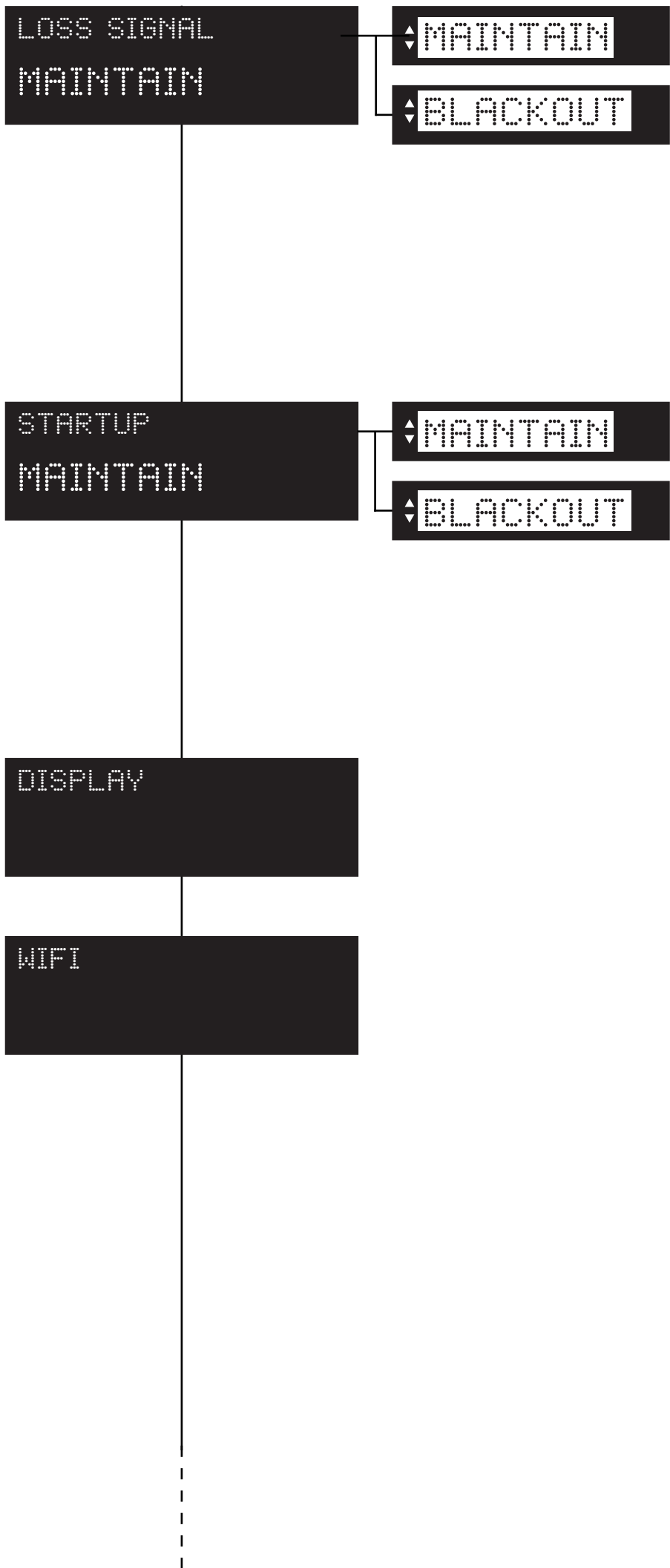

LOSS SIGNAL:

It is possible to choose between “maintain” (this function allows to keep the settings even in case of **LOSS SIGNAL**) and “blackout” (in case of **LOSS SIGNAL**, the projector will go into blackout).

STARTUP:

It is possible to choose between “maintain” (this function allows to keep the settings in case of **STARTUP**) and “blackout” (in case of **STARTUP**, the projector will go into blackout).

DISPLAY:

Display settings
(section **DISPLAY**)

WIFI:

Wi-Fi settings
(section **WIFI - OPTIONAL**)

10.5 Display

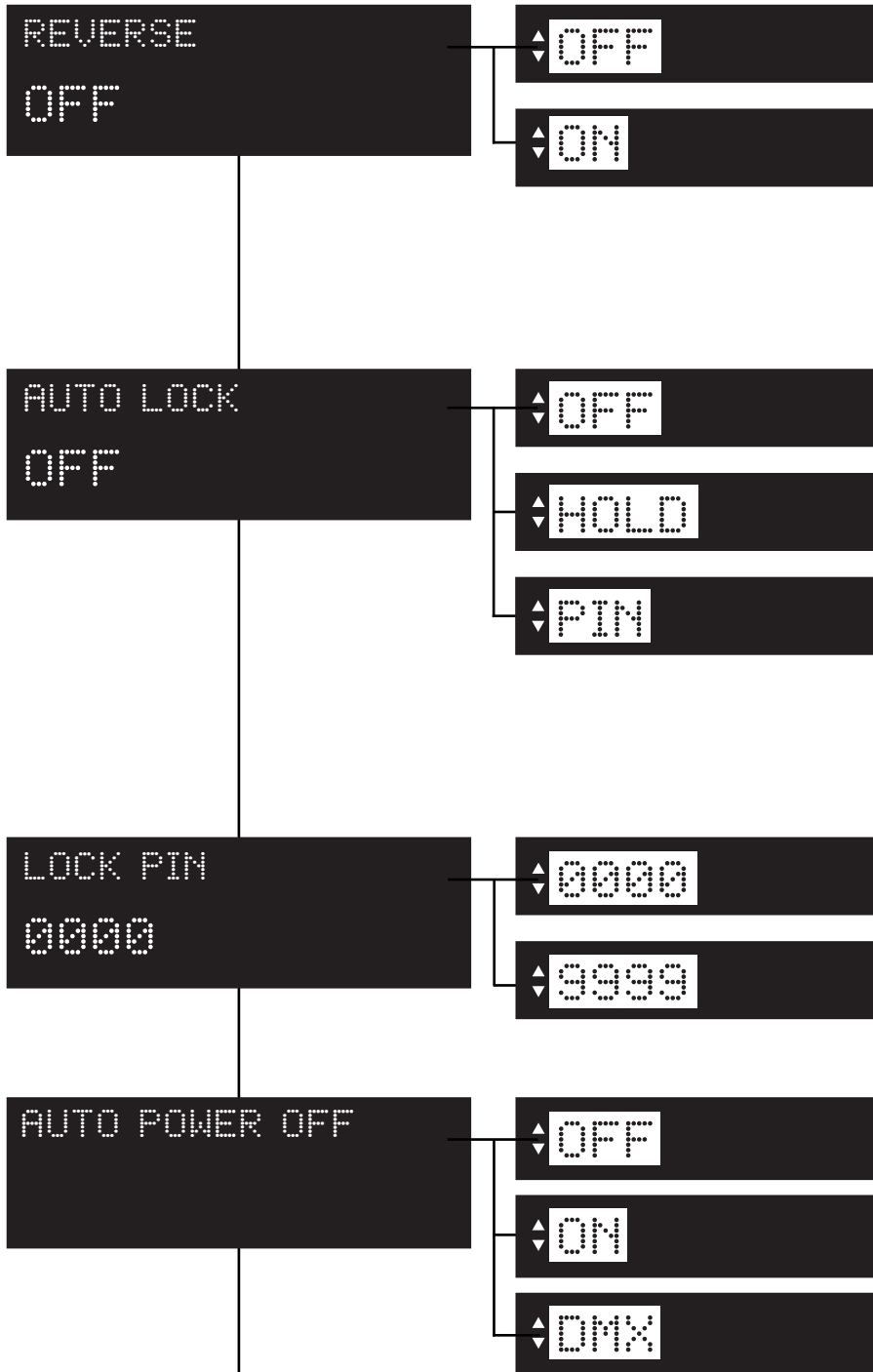

REVERSE:

It allows to turn by 180° the reading of the display. When you chose “**ON**” wait the turn of the display without clicking.

AUTO LOCK:

Locks the keys.

OFF: Auto Lock function in OFF

HOLD: Press any key for 3 seconds to unlock.

PIN: Use your personal lock pin to unlock.

LOCK PIN:

Allows to set your personal lock pin (from 0000 to 9999).

AUTO POWER OFF:

OFF: Auto Power OFF in OFF

ON: Causes the projector display to turn off after 30 seconds of inactivity.

DMX: Causes the projector display to turn off after 30 seconds of inactivity, but the display will turn automatically ON in case of signal loss

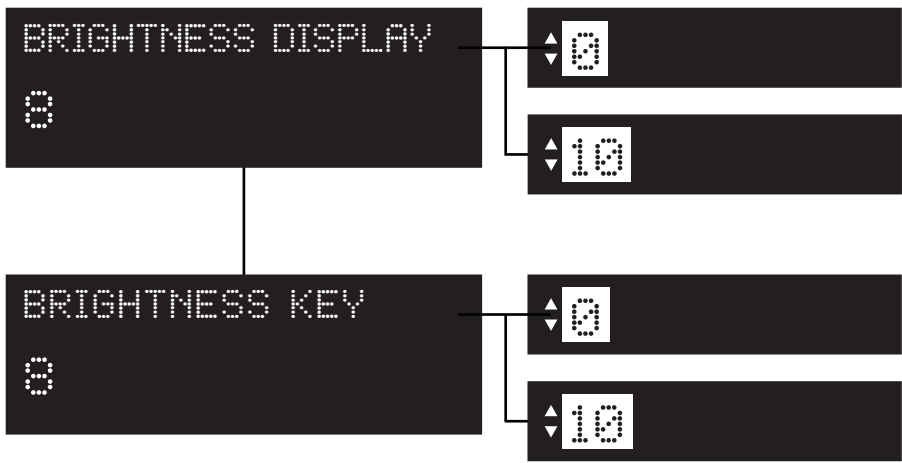

BRIGHTNESS DISPLAY:

Allows to change the brightness of the display (from 0 to 10).

BRIGHTNESS KEY:

Allows to change the brightness of the key (from 0 to 10).

10.6 Effects

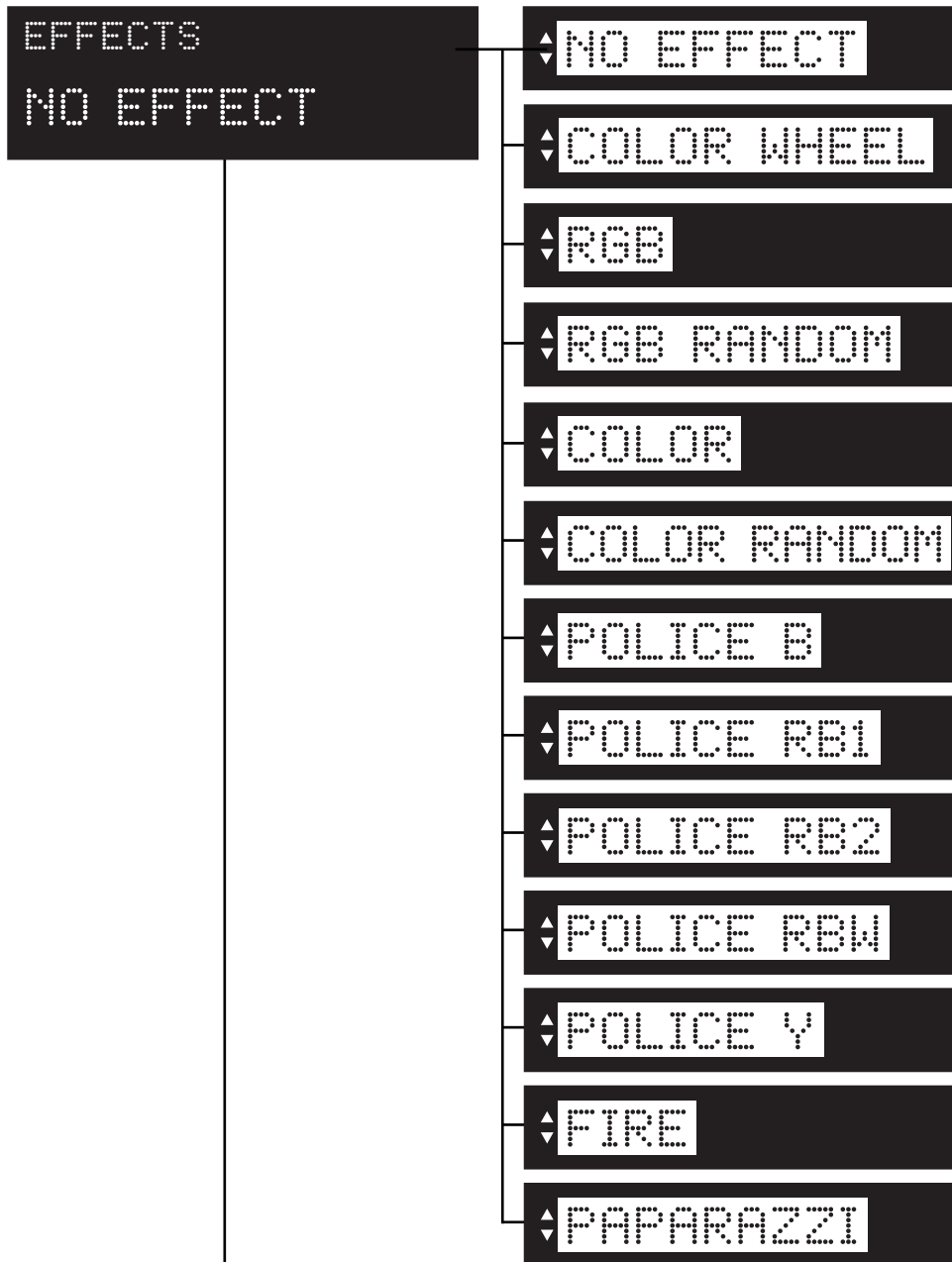

EFFECTS:

It is possible to choose between the following effects:

COLOR WHEEL: replicates the color wheel by applying a fade effect between colors (Red, Yellow, Green, Cyan, Blue, Magenta);

RGB: replicates the RGB colors in rotation following the order Red, Green, Blue;

RGB RANDOM: replicates randomly the RGB colors in rotation

COLOR: replicates the color wheel (Red, Yellow, Green, Cyan, Blue, Magenta);

COLOR RANDOM: replicates randomly the color wheel (Red, Yellow, Green, Cyan, Blue, Magenta);

POLICE B: replicates the police flashing lights (type B);

POLICE RB1: replicates the police flashing lights (type RB1);

POLICE RB2: replicates the police flashing lights (type RB2);

POLICE RBW: replicates the police flashing lights (type RBW);

POLICE Y: replicates the yellow police flashing lights;

FIRE: replicates the effect of fire from minimum (candle type) to maximum (blaze type);

PAFARAZZI: replicates the Paparazzi effect, a random flashing white light.

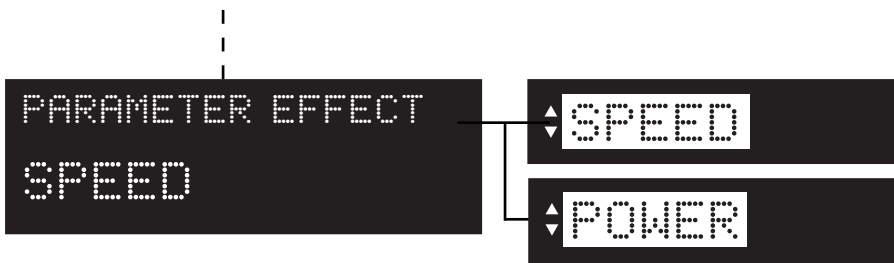

PARAMETER EFFECT:

It allows to change the parameter of the effect selected.

SPEED: increases the speed of all effects;

POWER: increases the intensity of all effects;

N.B. When you select a parameter effect it works for all effects and not individually.

Here below a chart where you can see which parameter works with the associated effect.

PARAMETER EFFECT	Speed	Power
Color Wheel	●	/
RGB	●	/
RGB Random	●	/
Color	●	/
Color Random	●	/
Police B	/	/
Police RB1	/	/
Police RB2	/	/
Police RBW	/	/
Police Y	/	/
Fire	●	●
Paparazzi	●	/

10.7 Measures

```
TEMPERATURES
 ° F    MIN NOW MAX
LED:    -°C -°C -°C
BOARD:  -°C -°C -°C
```

```
TEMP HISTORIES
 ° F    MIN NOW MAX
LED:    -°C -°C -°C
BOARD:  -°C -°C -°C
```

```
DMX INPUT
1  0
```

```
1
8
```

```
DMX REFRESH RATE
0 HZ
```

```
FAN STATUS
      %    RPM
LED:  -    -
AUX:  -    -
```

TEMPERATURES:

Shows the current temperature values of the fixture.

LED: shows the LED module temperature.

BOARD: shows the electronic board temperature.

TEMPERATURES HISTORIES:

Shows the history temperature of the fixture.

LED: shows the LED module temperature.

BOARD: shows the electronic board temperature.

DMX INPUT:

Shows the value of the DMX channels received by the fixture on every channel (from 1 to 5) that the fixture occupies on the line.

DMX REFRESH RATE:

Shows the refresh rate of the DMX signal sent by the console.

FAN STATUS:

Shows the percentage fan usage.

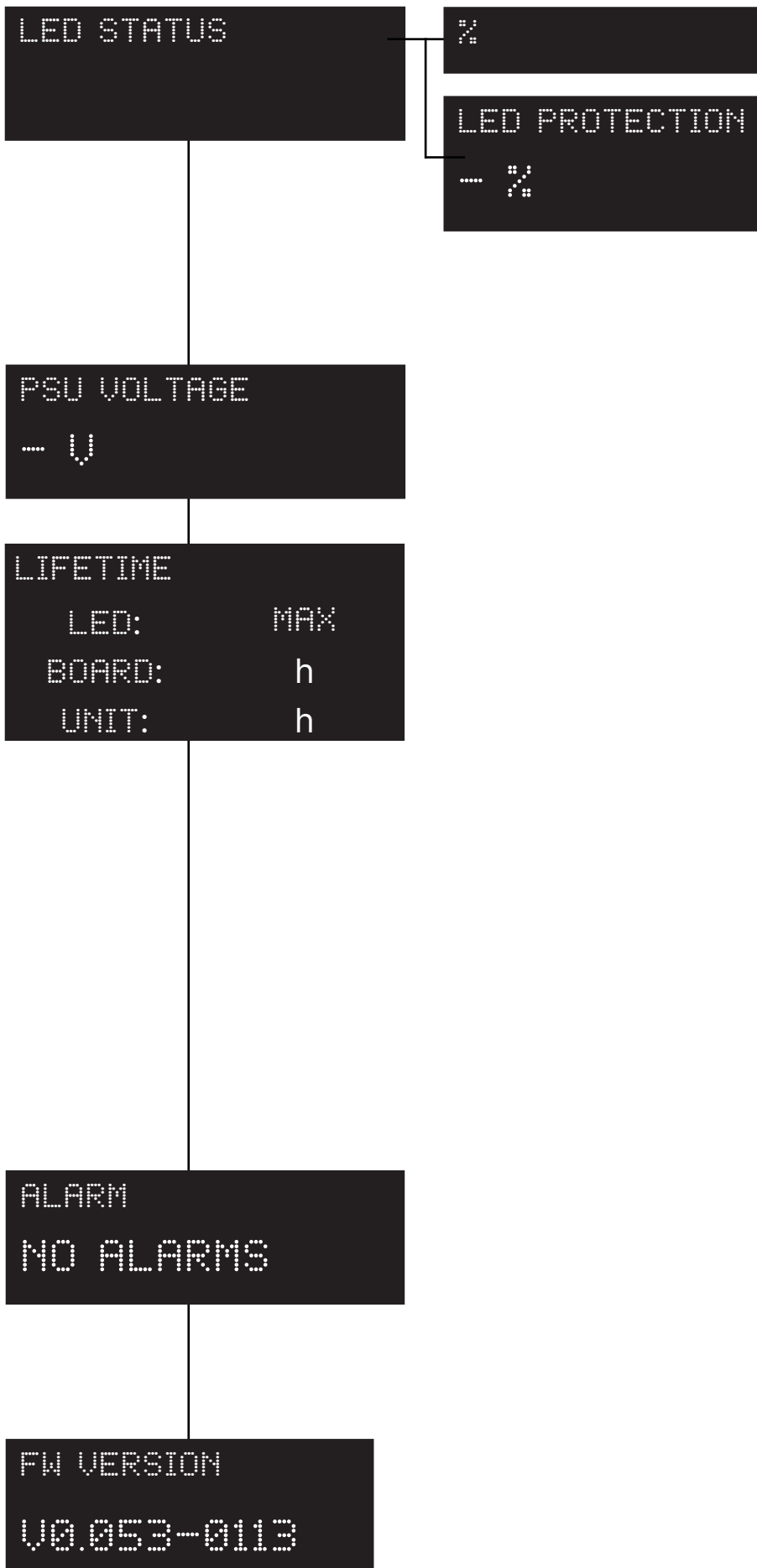

LED STATUS:

Shows the percentage value of the LED status.

LED PROTECTION:

Percentage of the maximum power in order to keep the projector in temperature.

PSU VOLTAGE:

Shows the power supply voltage.

LIFETIME:

Shows the hour counter of the fixture.

LED: shows the overall LED module life.

BOARD: shows the overall LED module life currently installed. **UNIT LIFE:** shows the overall hours of life of the fixture.

Note: this items can be reset in case of LED module replacement.

ALARM:

This menu eventually shows the alarm statuses if there is any (section **ERROR MESSAGES**).

FIRMWARE VERSION:

Shows the firmware version currently installed in the fixture (as you can see in the example).

11. Wi-Fi Menu (OPTIONAL)

11.1 Wi-Fi

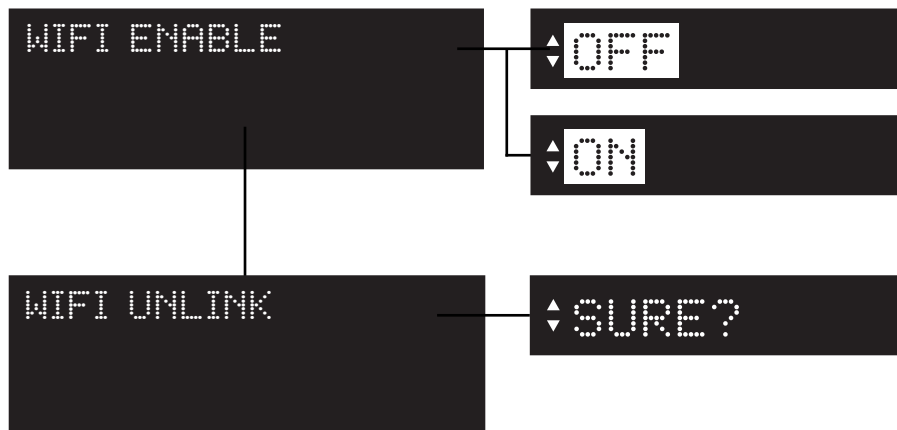

WIFI ENABLE:

It allows enable all the Wi-Fi functions

WIFI UNLINK:

This function is used to disconnect the projector from the transmitter.

12. Special Function and Error Messages

12.1 Special functions of the fixture

Storing the DMX signal

To use the fixture without an active DMX console it is possible to store the DMX settings in two ways:

- Through the **PRESET** menu;
- Disconnecting the DMX signal when the fixture is on. When the signal is unconnected the fixtures stores the signal;

Automatic fan standby

To decrease the noise and the power consumption the cooling fan turns off after 40 seconds without emitting light.

12.2 Error messages

If a malfunction occurs, **LEDko EXT FS RGBLA +** has a self-diagnostic system that will show the error message on the display. The following table will explain in detail the most common errors. If, despite of suggested intervention, the problem persists, call the **Coemar** Service Center.

Error code	Description
MEMORY	Memory Error Indicates that the projector has lost its memory and saved data
HW MEMORY	HW Memory Error Indicates that there is an Hardware Memory Error
DMX ADDR	DMX Address Error The projector address is too high and does not allow to receive all the necessary channels. We recall in this connection that some controllers do not generate all the 512 channels.
NTC ERROR	NTC Error LED temperature sensor missing or damaged.
SHORT NTC	Short NTC Error Error of the LED's sensor circuit.
FAN SPEED	Fan Speed Error Auto diagnostic routine found that the Fan may be damaged, contact Coemar assistance for the module replacement. IMPORTANT: to ensure the sensor is giving correct readings or that the fan rotates correctly, set the fan to the maximum level.
OVERTEMP	Over temperature Error Indicates that the product has reached a too high temperature.

13. Accessories and spare parts

LEDko EXT FS RGBLA + is a very versatile fixture, optional accessories for its customization are available under request:

Accessory name	Code
Profile Zoom 10°-25°	BC10029A002
Profile Zoom 14°-35°	BC10029A000
Profile Zoom 30°-60°	BC10029A004
Lens Tube Profile 80°	BC10029A005
Removable four blade framing system with gobo holder	BC10028A000
Frame Holder (included)	BC10029A003
LEDko EXT DMX wireless kit	BC10029A100
DMX end of line closure cap (indispensable for the last projector of the line)	RME34/G

All the components of **LEDko EXT FS RGBLA +** are available as spare parts from your Coemar dealer or Service. Accurate description of the fixture, model number and type will assist us in providing for your requirements in an efficient and effective manner.

14. Maintenance

14.1 Firmware update

The firmware of **LEDko EXT FS RGBLA +** can be updated through the RDM protocol (ANSI E1.20). Contact Coemar assistance to receive the software and the device updater (AC10011A000).

14.2 Periodic cleaning

Lenses

Even a thin layer of dust can reduce the luminous output and alter the consistency of the beam. Regularly clean all filters and lenses using a soft cotton cloth, dampened with a special lens cleaning solution.

Cleaning of the unit

Use a soft brush or a common vacuum cleaner or a source of compressed air for removing dust. For the cleaning of the housing use a soft cloth and a non-aggressive cleaner. Check that the internal fans and heat exchanger must be perfectly clean.

14.3 Periodic controls

Mechanical components

Check the correct working of the mechanical parts and, if needed, replace them. Make sure the projector is not mechanically damaged. If necessary, replace the worn parts.

Electrical components

Check all electrical connections, in particular for correct grounding and correct attachment of all extractable connectors. Press the connectors if necessary and reposition as before.

15. F.A.Q. and answers

The following list shows common issues that may be simply solved. If issues persist, the unit must be repaired by a qualified personnel or just contact your **Coemar** service near you.

Question	Possible solution
LEDko EXT FS RGLA + does not emit light	Projector not powered on: <ul style="list-style-type: none">• Make sure the power cord is plugged in or test the input voltage. Wrong DMX address: <ul style="list-style-type: none">• Check the DMX Address setting and the output signal of the controller.
LEDko EXT FS RGLA + is not responding to DMX signal	DMX signal may not reach LEDko EXT FS RGLA +: <ul style="list-style-type: none">• Inspect the cable connection, correct poor connections or inefficient repair or replace damaged cables.• Check DMX address of the unit.

Help from Coemar Technical Services

If you are having difficulties and your problem is not addressed by this document, contact Coemar Technical Services directly at one of this email address:

info@coemar.com / service@coemar.com

Or call the number **+39 0376 1514412**

When calling for help, take these steps first:

- Prepare a detailed description of the problem
- Go near the equipment for troubleshooting

User notes

.....
.....
.....
.....
.....
.....
.....
.....
.....
.....
.....
.....
.....
.....
.....
.....
.....
.....
.....
.....
.....
.....
.....
.....
.....
.....
.....
.....
.....
.....
.....
.....
.....
.....
.....
.....
.....
.....
.....
.....
.....
.....



Information on disposal of the equipment

The equipment at the end of its useful life must be disposed of at an appropriate recycling center for waste electrical and electronic equipment. The treatment and disposal of environmentally friendly, helps prevent potential negative environmental and health and promote the reuse and / or recycling of materials making up the equipment. Illegal disposal by the user includes the application of administrative sanctions provided by law.



Coemar Lighting s.r.l.

Via Carpenedolo 90
46043 Castiglione delle Stiviere, Mantova, Italy
phone. +39 0376/1514412 - fax +39 0376/1514380
info@coemar.com

Coemar reserves the right to change specifications without prior notice